

XZII DIMENSIONAL DRAWINGS

REMOTE MOUNTED FILTER AND MEMBRANE OPTIONS

MODULAR UNITS REMOTE MOUNTED FILTERS AND MEMBRANES

STACKED UNITS REMOTE MOUNTED FILTERS AND MEMBRANES

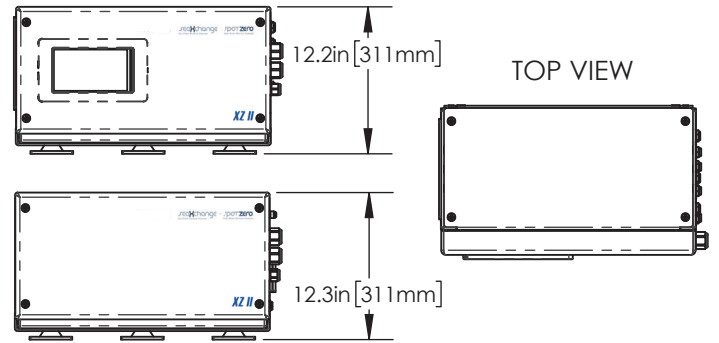
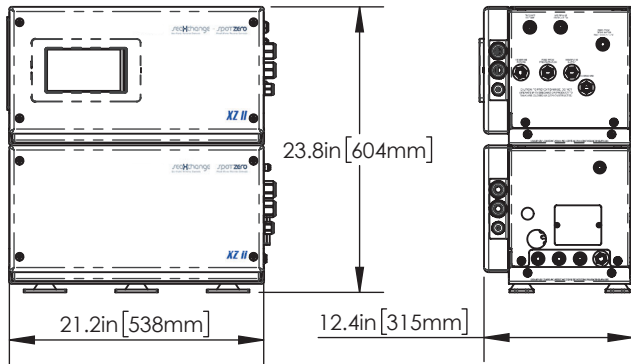

LOCALLY MOUNTED MEMBRANE OPTIONS

TOP VIEW

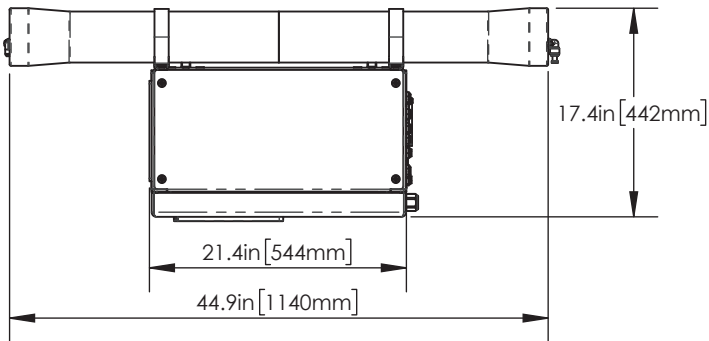

LOCALLY MOUNTED FILTER OPTIONS

TOP VIEW

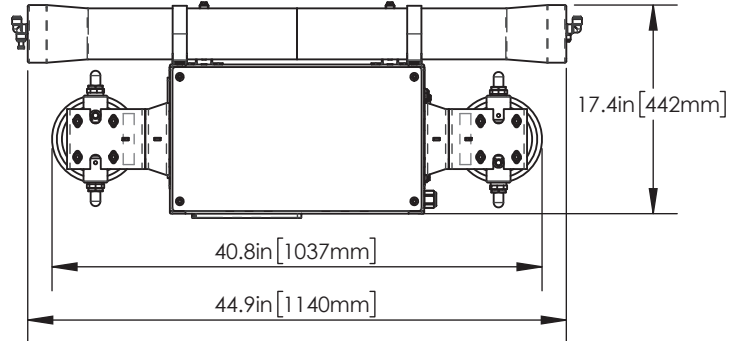

MODULAR UNITS LOCALLY MOUNTED MEMBRANES

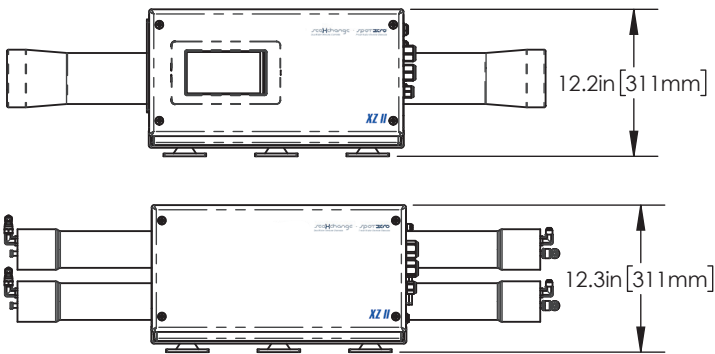

STACKED UNITS LOCALLY MOUNTED FILTERS

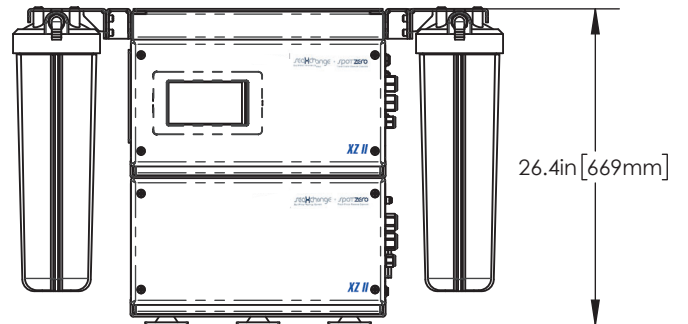

STACKED UNITS LOCALLY MOUNTED MEMBRANES

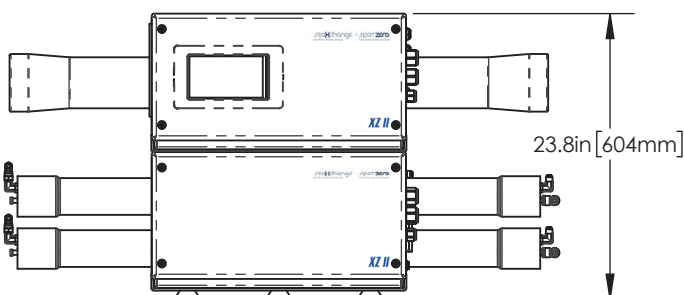

STACKED UNITS LOCALLY MOUNTED FILTERS AND MEMBRANES

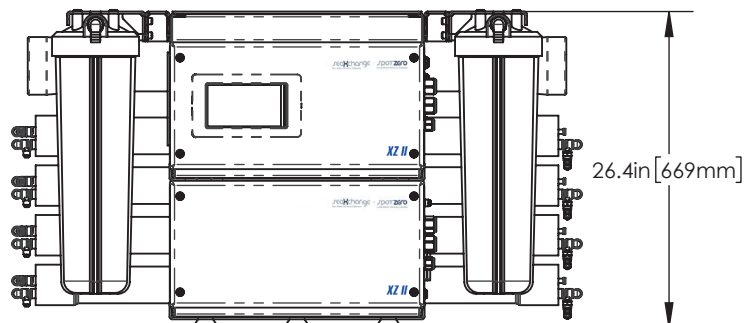

SW COMMERCIAL PRE-FILTER
4.5" x 20" HOUSING

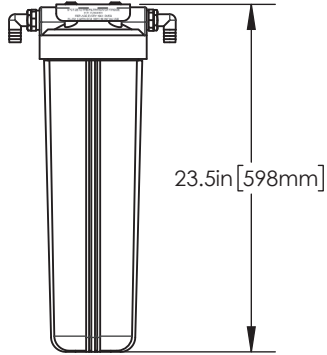
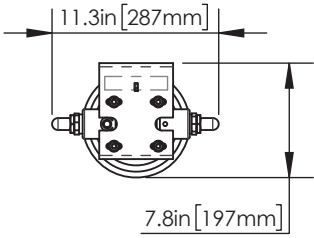

FW COMMERCIAL PRE-FILTER
4.5" x 20" HOUSING

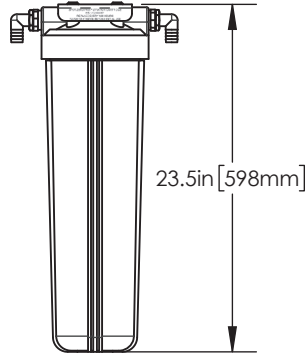
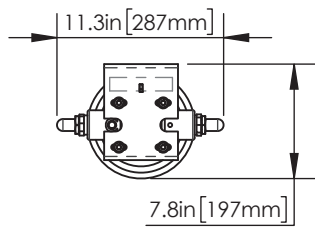

FW MEMBRANES

2000 GPD (7570 LPD)
REMOTE OR LOCAL MOUNT

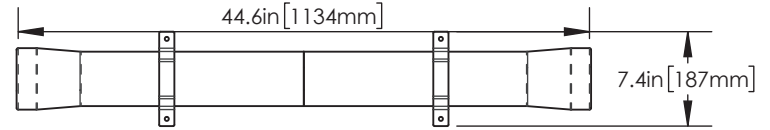

3000 GPD (11350 LPD)
REMOTE OR LOCAL MOUNT

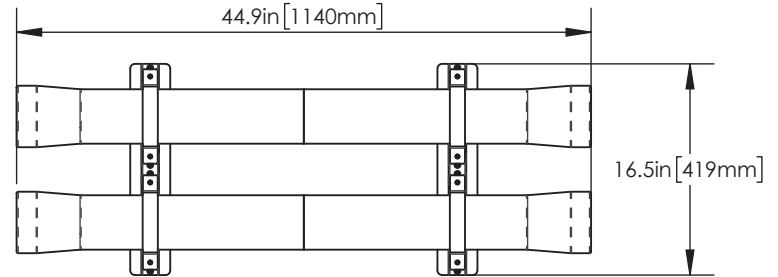

BACTERIOSTATIC REMINERALIZER
2.5" X 10" HOUSING

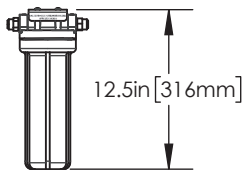
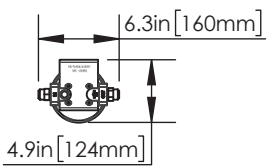

FRESH WATER FLUSH
2.5" X 10" HOUSING

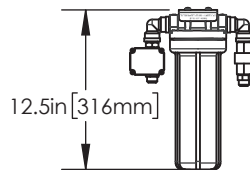
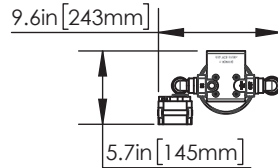

SW MEMBRANES

900 GPD (3407 LPD)
LOCAL MOUNT ONLY POSSIBLE ON STACKED SYSTEM

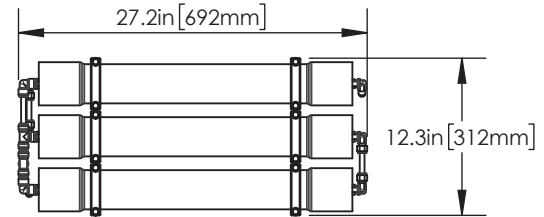

1200 GPD (4540 LPD)
LOCAL MOUNT POSSIBLE ON MODULAR AND STACKED

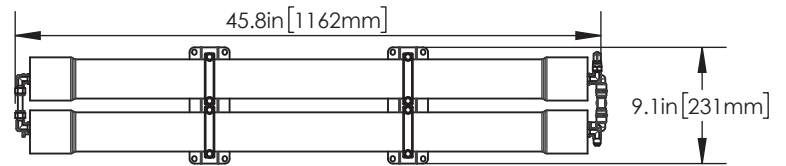

1800 GPD (6810 LPD)
LOCAL MOUNT ONLY POSSIBLE ON STACKED SYSTEM

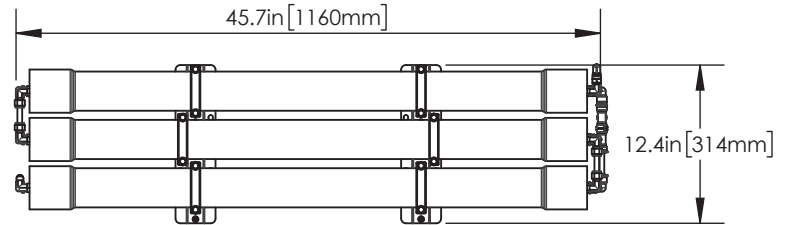

2200 GPD (8325 LPD)
LOCAL MOUNT ONLY POSSIBLE ON STACKED SYSTEM

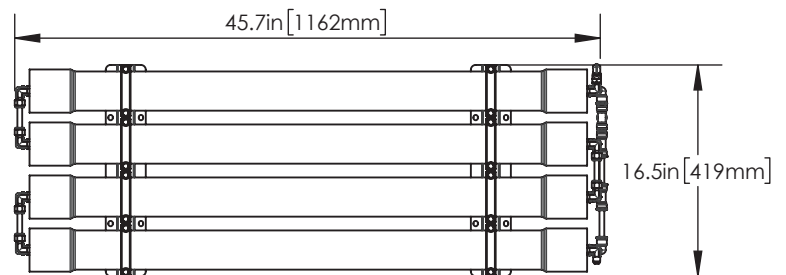

SW BOOST PUMP

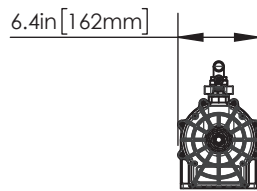
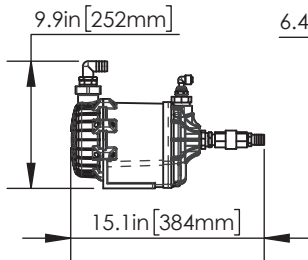

OPTIONAL EQUIPMENT

WALL BRACKET
SUPPORTS MODULAR OR STACKED UNITS

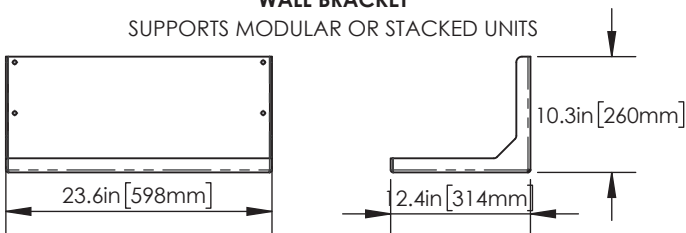

ADDITIONAL REMOTE MOUNTED 7-INCH TOUCHSCREEN

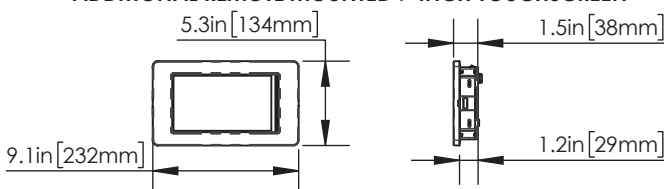

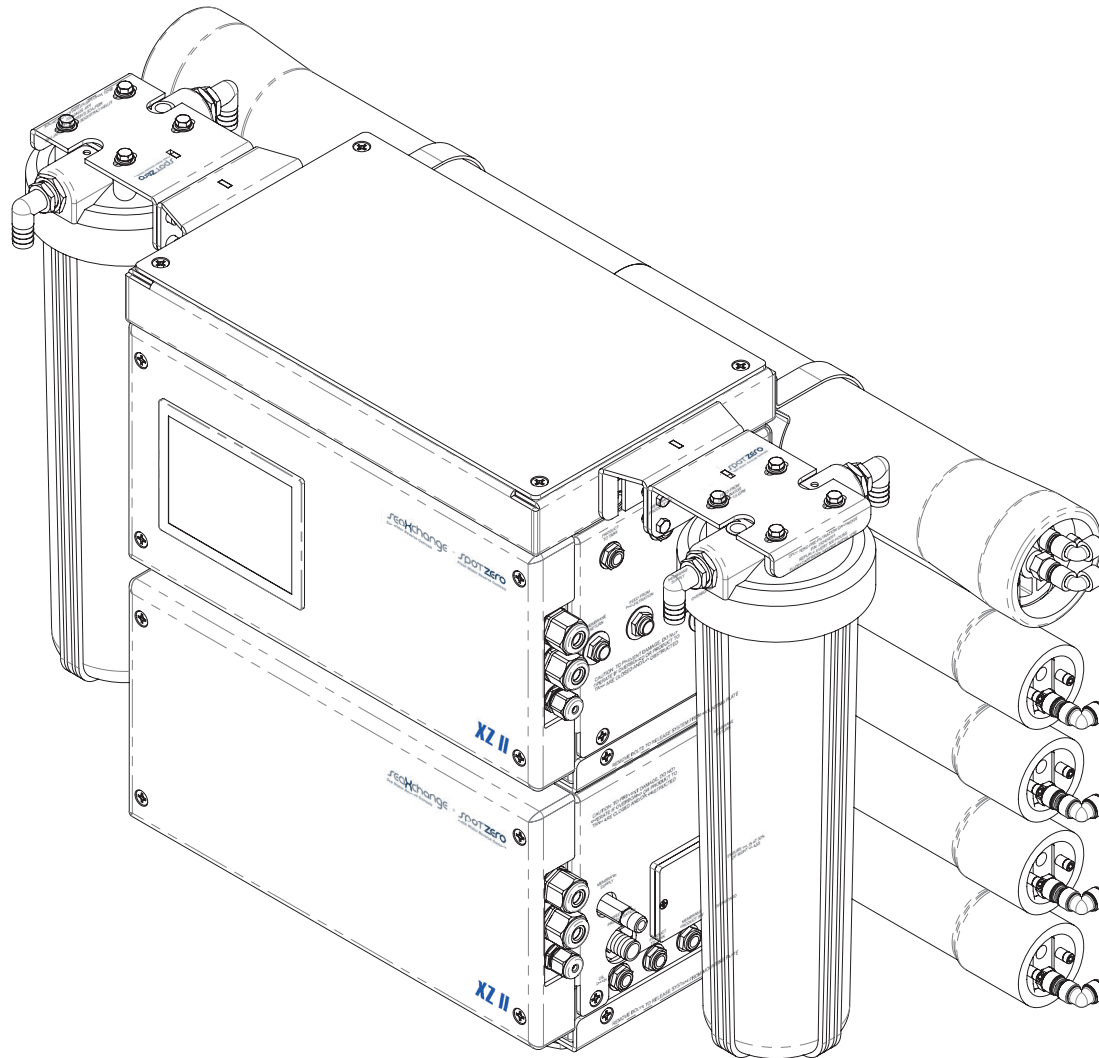

P/N: XZII-2200-2000-S

	NAME	DATE
DRAWN	ES	12/23/20
CHECKED		
ENG APPR.		
MFG APPR.		
Q.A.		



XZII DIMENSIONAL DRAWING

SCALE: 1:7 DWG. NO. DD0002-01 SHEET 1 OF 2 DWG. REV B

UNLESS OTHERWISE SPECIFIED:
 DIMENSIONS ARE IN INCHES
 TOLERANCES: ±.015
 FRACTIONAL: ±1/32
 ANGULAR: MACH: ±1/2 BEND ±1
 TWO PLACE DECIMAL ±.010
 THREE PLACE DECIMAL ±.005

PROPRIETARY AND CONFIDENTIAL
 THE INFORMATION CONTAINED IN THIS DRAWING IS THE SOLE PROPERTY OF SPOT ZERO. ANY REPRODUCTION IN PART OR AS A WHOLE WITHOUT THE WRITTEN PERMISSION OF SPOT ZERO IS PROHIBITED.

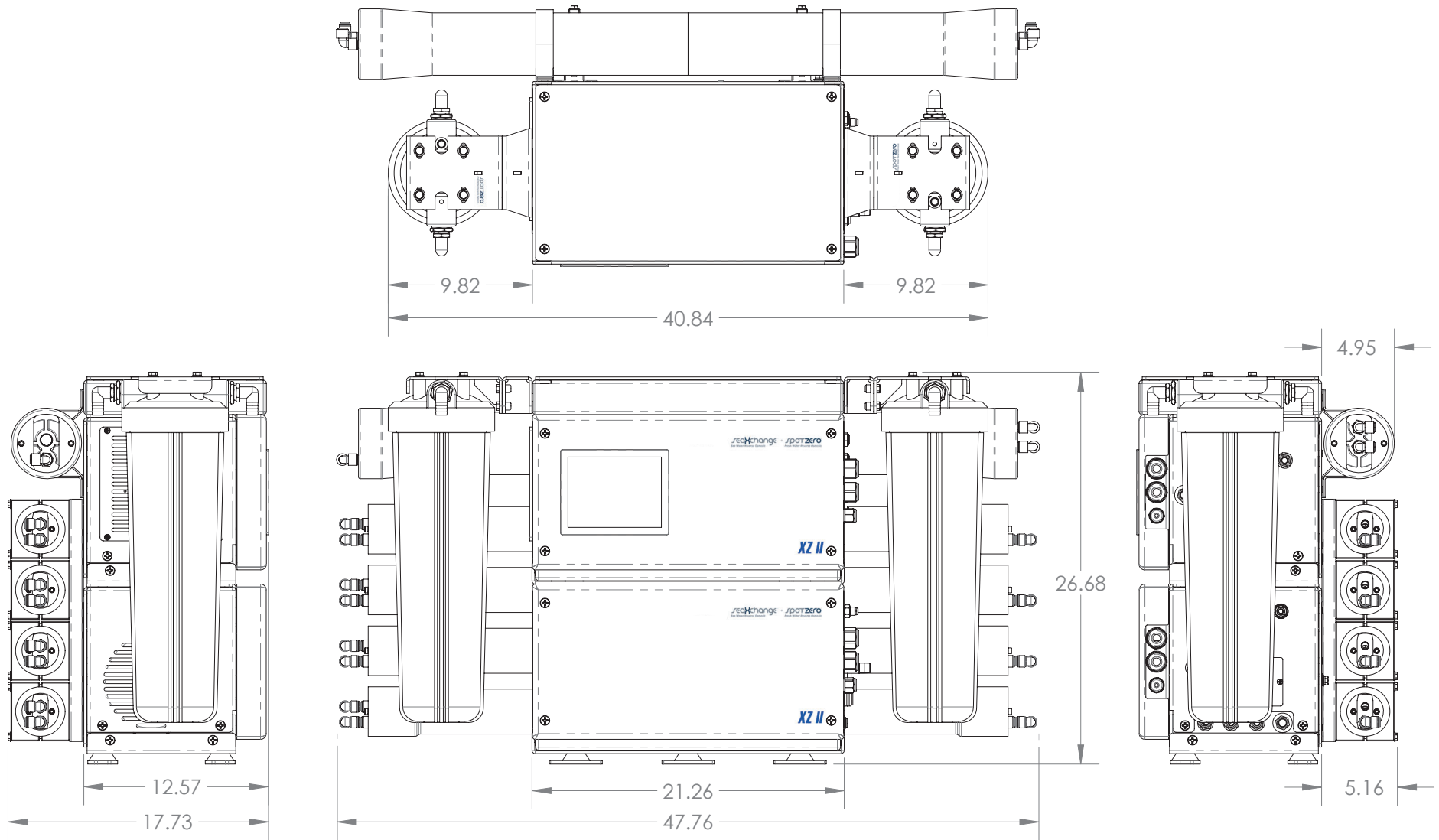

P/N: XZII-2200-2000-S

PROPRIETARY AND CONFIDENTIAL
 THE INFORMATION CONTAINED IN THIS DRAWING IS THE SOLE PROPERTY OF SPOT ZERO. ANY REPRODUCTION IN PART OR AS A WHOLE WITHOUT THE WRITTEN PERMISSION OF SPOT ZERO IS PROHIBITED.

UNLESS OTHERWISE SPECIFIED:
 DIMENSIONS ARE IN INCHES
 TOLERANCES: ±.015
 FRACTIONAL: ±1/32
 ANGULAR: MACH: ±1/2 BEND ±1
 TWO PLACE DECIMAL ±.010
 THREE PLACE DECIMAL ±.005

	NAME	DATE
DRAWN	ES	12/23/20
CHECKED		
ENG APPR.		
MFG APPR.		
Q.A.		



XZII DIMENSIONAL DRAWING

SCALE: 1:10	DWG. NO. DD0002-01	SHEET 2 OF 2	DWG. REV B
-------------	--------------------	--------------	------------

A Product to Tank → Feed From Desalinator

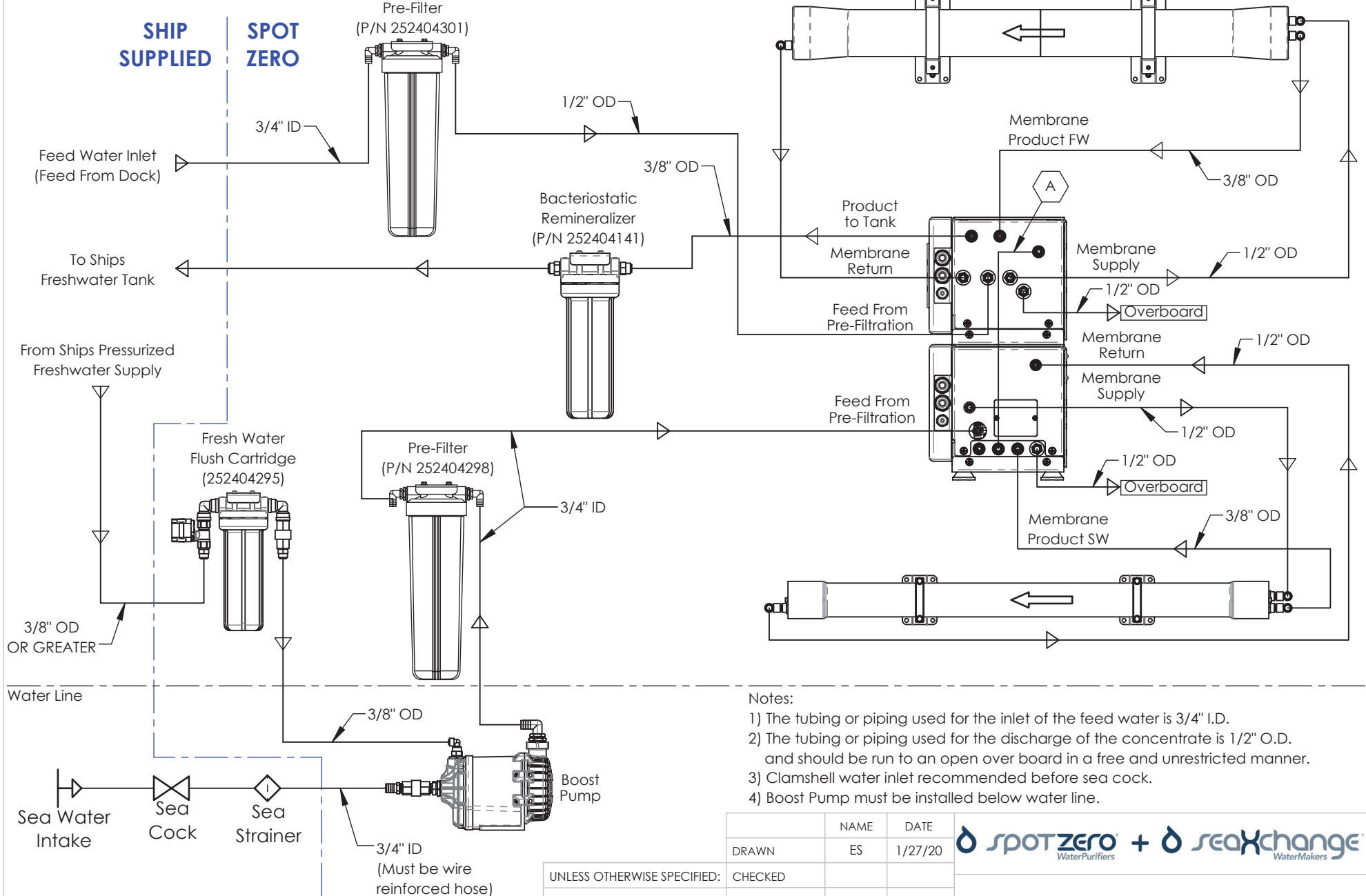

- Notes:
- 1) The tubing or piping used for the inlet of the feed water is 3/4" I.D.
 - 2) The tubing or piping used for the discharge of the concentrate is 1/2" O.D. and should be run to an open over board in a free and unrestricted manner.
 - 3) Clamshell water inlet recommended before sea cock.
 - 4) Boost Pump must be installed below water line.

PROPRIETARY AND CONFIDENTIAL
 THE INFORMATION CONTAINED IN THIS DRAWING IS THE SOLE PROPERTY OF SPOT ZERO. ANY REPRODUCTION IN PART OR AS A WHOLE WITHOUT THE WRITTEN PERMISSION OF SPOT ZERO IS PROHIBITED.

UNLESS OTHERWISE SPECIFIED:
 DIMENSIONS ARE IN INCHES
 TOLERANCES: ±.015
 FRACTIONAL: ±1/32
 ANGULAR: MACH: ±1/2 BEND ±1
 TWO PLACE DECIMAL ±.010
 THREE PLACE DECIMAL ±.005

	NAME	DATE
DRAWN	ES	1/27/20
CHECKED		
ENG APPR.		
MFG APPR.		
Q.A.		



XZII One Line Flow Drawing

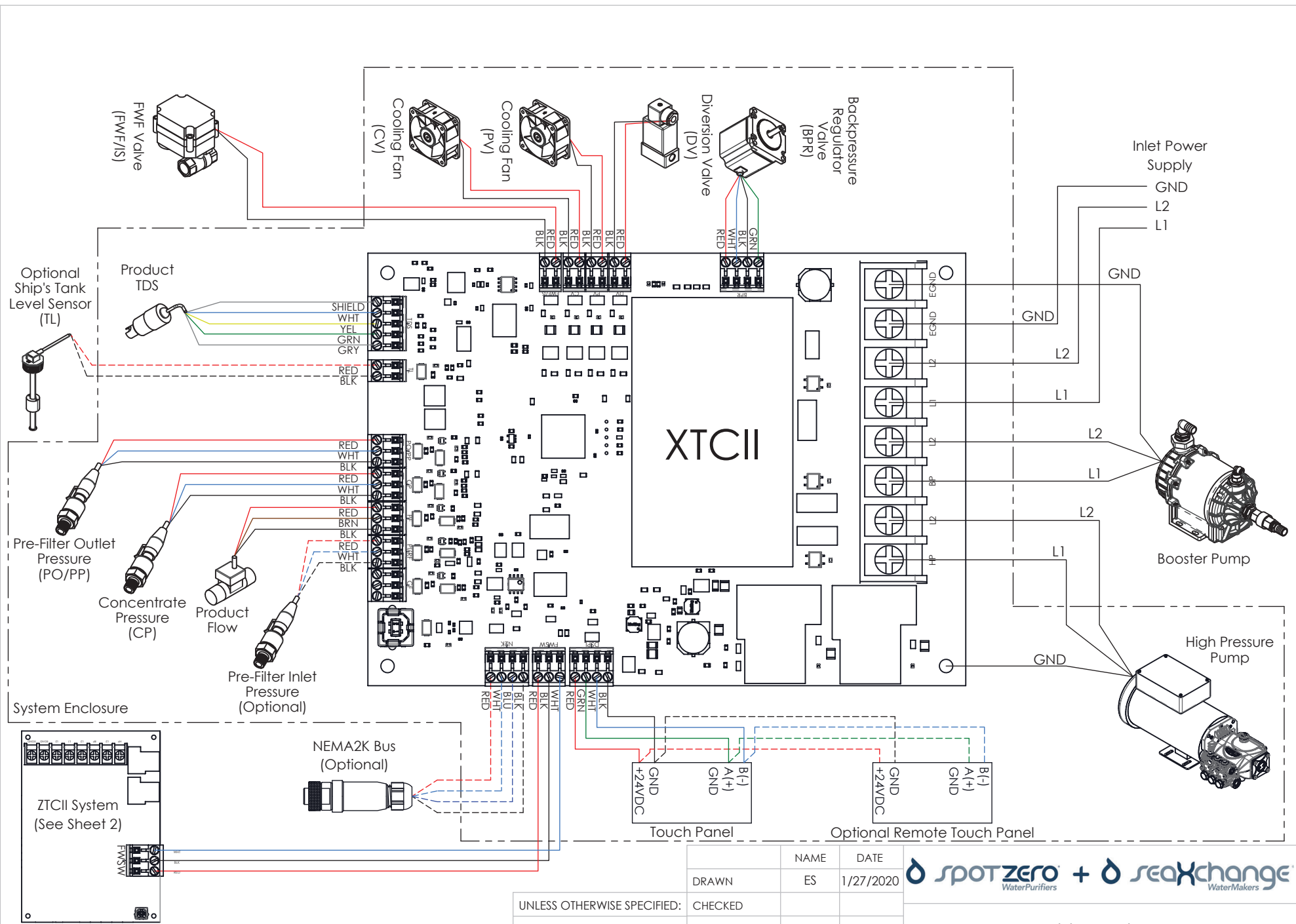

PROPRIETARY AND CONFIDENTIAL
 THE INFORMATION CONTAINED IN THIS DRAWING IS THE SOLE PROPERTY OF SPOT ZERO. ANY REPRODUCTION IN PART OR AS A WHOLE WITHOUT THE WRITTEN PERMISSION OF SPOT ZERO IS PROHIBITED.

UNLESS OTHERWISE SPECIFIED:
 DIMENSIONS ARE IN INCHES
 TOLERANCES: ±.015
 FRACTIONAL: ±1/32
 ANGULAR: MACH: ±1/2 BEND ±1
 TWO PLACE DECIMAL ±.010
 THREE PLACE DECIMAL ±.005

	NAME	DATE
DRAWN	ES	1/27/2020
ENG APPR.		
MFG APPR.		
Q.A.		



XZII Wiring Diagram

NOTE: SEE SHEET 3 FOR
OPTIONAL TANK LEVEL
SWITCH INSTALLATION

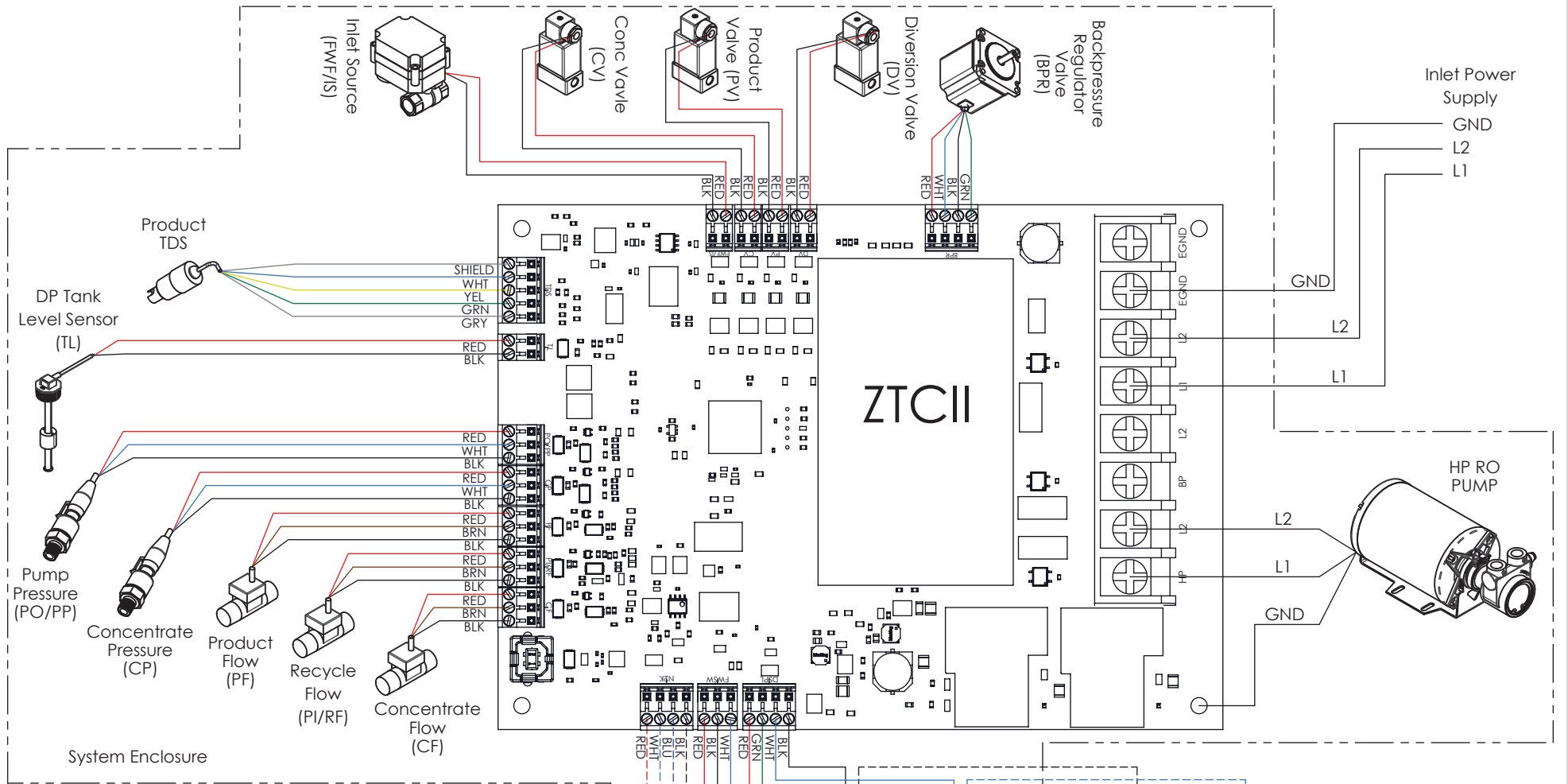

PROPRIETARY AND CONFIDENTIAL
THE INFORMATION CONTAINED IN THIS DRAWING IS THE SOLE PROPERTY OF SPOT ZERO. ANY REPRODUCTION IN PART OR AS A WHOLE WITHOUT THE WRITTEN PERMISSION OF SPOT ZERO IS PROHIBITED.

UNLESS OTHERWISE SPECIFIED:

DIMENSIONS ARE IN INCHES
TOLERANCES: ±.015
FRACTIONAL: ±1/32
ANGULAR: MACH: ±1/2 BEND ±1
TWO PLACE DECIMAL ±.010
THREE PLACE DECIMAL ±.005

	NAME	DATE
DRAWN	ES	1/27/2020
ENG APPR.		
MFG APPR.		
Q.A.		



XZII Wiring Diagram

SCALE: NTS DWG. NO. ED1002-01 SHEET 2 OF 3 DWG. REV E

REVISIONS

REV.	DESCRIPTION	DATE	FIRST APPROVAL	SECOND APPROVAL
D	SYSTEM ENCLOSURE EXPANDED TO INCLUDE THE HGIH PRESSURE PUMP	6/10/2021		
E	SHEET 3 ADDED TO INCLUDE REVISION TABLE ADN OPTIONAL TANK LEVEL SWITCH INSTALLATION	11/1/2021	<i>JP</i>	JJ

OPTIONAL TANK LEVEL SWITCH INSTALLATION

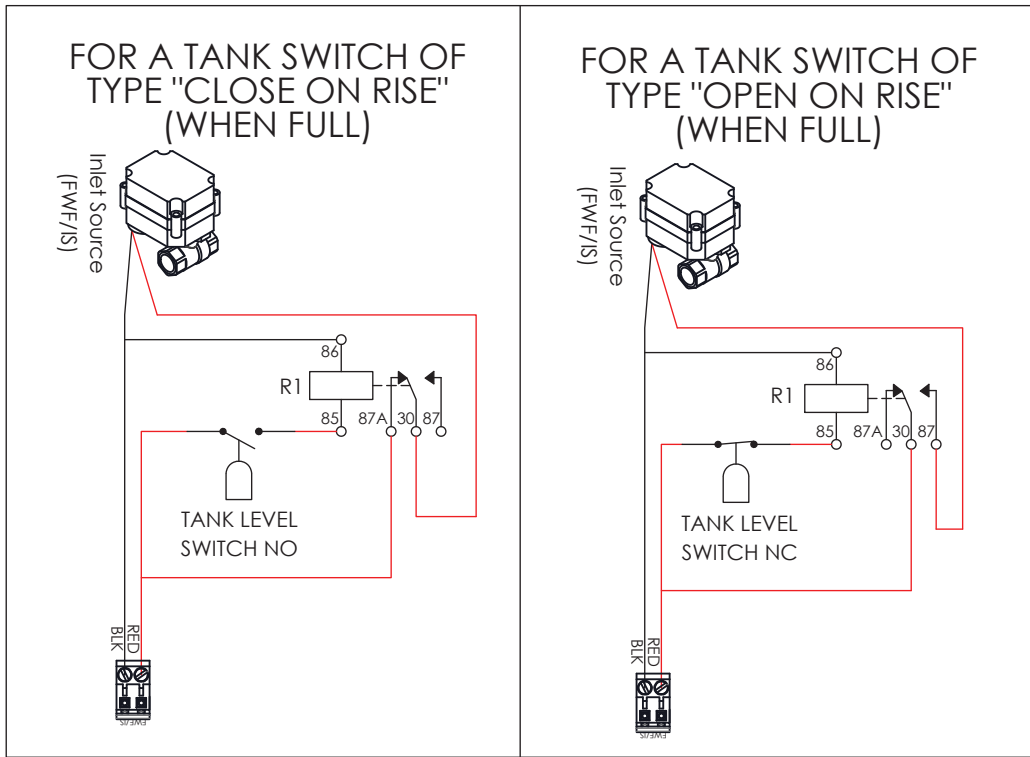

ID#	DESCRIPTION	MANUFACTURE	PART NUMBER
R1	AUTOMOTIVE STYLE SPDT RELAY WITH 24V COIL	PANASONIC ELECTRIC WORKS	CB1-M-24V (OR EQUIVALENT)

PROPRIETARY AND CONFIDENTIAL
 THE INFORMATION CONTAINED IN THIS DRAWING IS THE SOLE PROPERTY OF SPOT ZERO. ANY REPRODUCTION IN PART OR AS A WHOLE WITHOUT THE WRITTEN PERMISSION OF SPOT ZERO IS PROHIBITED.

UNLESS OTHERWISE SPECIFIED:
 DIMENSIONS ARE IN INCHES
 TOLERANCES: ±.015
 FRACTIONAL: ±1/32
 ANGULAR: MACH ±1/2 BEND ±1
 TWO PLACE DECIMAL ±.010
 THREE PLACE DECIMAL ±.005

	NAME	DATE
DRAWN	ES	1/27/2020
CHECKED		
ENG APPR.		
MFG APPR.		
Q.A.		



XZII Wiring Diagram