



## USERS MANUAL / INSTALLATION GUIDE



# SZ III

**SZIII-2000**

**SZIII-3000**

[www.spotzerowater.com](http://www.spotzerowater.com)

# Table of Contents

<b>Introduction .....</b>	<b>4</b>
Congratulations .....	5
Acronyms and Definitions .....	5
Safety.....	5
Principles of Reverse Osmosis .....	6
Unit Specifications.....	7
<b>Installation and Commissioning.....</b>	<b>8</b>
SZIII Install Kit .....	9
System Requirements and Operation Guidelines .....	10
<i>Plumbing.....</i>	<i>10</i>
<i>Tube Cutting and Installation Procedure for Quick Connect Fittings</i>	<i>10</i>
<i>Electrical.....</i>	<i>11</i>
SZIII Wiring Diagram.....	12
SZIII One Line Flow Diagram .....	13
<i>PRE-FILTRATION.....</i>	<i>14</i>
<i>Pre-Filtration Plumbing.....</i>	<i>14</i>
<i>Overboard Connection .....</i>	<i>15</i>
<i>Product to Tank Connection.....</i>	<i>15</i>
<i>Feed From Watermaker.....</i>	<i>16</i>
<i>Membrane Supply.....</i>	<i>16</i>
<i>Membrane Return.....</i>	<i>17</i>
<i>Membrane Product.....</i>	<i>17</i>
<b>Operation and Maintenance .....</b>	<b>18</b>
Operation Specifications .....	19
<i>Feed Water Specifications .....</i>	<i>19</i>
System Standard Operating Parameters.....	20
<i>TEMPERATURE CORRECTION FACTORS FOR MEMBRANE         PRODUCTION .....</i>	<i>21</i>
<i>Rejection, Recovery, and Flow Rates .....</i>	<i>22</i>
Components of the SZIII Unit .....	23
<i>System Controller.....</i>	<i>23</i>
<i>Freshwater RO Pump .....</i>	<i>23</i>
<i>Membranes.....</i>	<i>23</i>
<i>Membrane Operation Guidelines .....</i>	<i>23</i>

<i>Membrane General Guidelines</i> .....	23
Membrane Replacement and Removal.....	24
<i>Inserting the New Membrane</i> .....	25
Preparing Unit for Storage or Shipment .....	27
<i>Preparing System for Storage:</i> .....	27
<i>Recommissioning the System After Storage</i> .....	28
Winterization For Your Unit .....	29
<i>Recommissioning the System After Winterization</i> .....	30
Remote LCD Keypad Setup.....	30
SZIII Consumable Items .....	31
<i>Operating Do's and Don'ts</i> .....	32
Initial Startup.....	32
LCD Touchpad Navigation .....	34
SZIII LCD Menu Tree .....	35
STANDARD OPERATION.....	36
Performing a Freshwater Flush .....	41
Bacteriostatic Remineralizer .....	41
<b>Troubleshooting</b> .....	<b>42</b>
Troubleshooting Guide.....	43
<i>Abnormal Product Flow</i> .....	43
IS MY SYSTEM WORKING PROPERLY? .....	44
<i>TDS REJECTION</i> .....	44
<i>Membrane Cleaning Procedure</i> .....	44
<i>Membrane Cleaning with Two Short 4.5"x10" Prefilters</i> .....	45
<i>Membrane Cleaning with 4.5"x20" Double Stack Prefilter</i> .....	45
<b>SZIII System Specification and Parts</b> .....	<b>46</b>
Bacteriostatic Remineralizer Assembly Drawing.....	47
SZIII Motor/Pump Assembly Drawing .....	48
SZIII Pre-Filter Assembly Drawing Double 4.5"x10" .....	49
Freshwater Double-Stack Commercial Pre-Filter Assembly Drawing ....	50
SZIII Pump Specifications and Information.....	51
<b>Warranty</b> .....	<b>55</b>

# Introduction

## Congratulations

Your Spot Zero™ SZIII-Series ultra-purification system is a durable piece of equipment that, with proper care, will last for many years. This user manual outlines installation, operation, maintenance, and troubleshooting details vital to the sustained performance of your system.

If your system is altered at the site of operation or if the feed water conditions change, please contact your local dealer or distributor to determine the proper recovery for your application.

NOTE: PRIOR TO OPERATING OR SERVICING THE REVERSE OSMOSIS SYSTEM, THE USER MANUAL MUST BE READ AND FULLY UNDERSTOOD. KEEP THIS AND OTHER ASSOCIATED INFORMATION FOR FUTURE REFERENCE AND FOR NEW OPERATORS OR QUALIFIED PERSONNEL NEAR THE SYSTEM.

## Acronyms and Definitions

ACRONYM/SYMBOLS	DEFINITION
FWF	FRESH WATER FLUSH
RO	REVERSE OSMOSIS
PSI	POUNDS PER SQUARE INCH
GPM	GALLONS PER MINUTE
GPD	GALLONS PER DAY
TDS	TOTAL DISSOLVED SOLIDS
PPM	PARTS PER MILLION
TCF	TEMPERATURE CORRECTION FACTOR
LP SWITCH	LOW PRESSURE SWITCH
HP SWITCH	HIGH PRESSURE SWITCH
Φ	PHASE
SW	SEA WATER
FW	FRESH WATER
QC	QUICK CONNECT

## Safety

The safety section of this User Manual outlines the various safety headings used throughout this manual's text and are enhanced and defined below.

<b>NOTE</b>	INDICATES STATEMENTS THAT PROVIDE FURTHER INFORMATION AND CLARIFICATION
-------------	---

 <b>CAUTION</b>	CAUTION: INDICATES STATEMENTS THAT ARE USED TO IDENTIFY CONDITIONS OR PRACTICES THAT COULD RESULT IN EQUIPMENT OR OTHER DAMAGE.
--	---

 <b>WARNING</b>	<b>WARNING: INDICATES STATEMENTS THAT ARE USED TO IDENTIFY CONDITIONS OR PRACTICES THAT COULD RESULT IN INJURY OR LOSS OF LIFE. FAILURE TO FOLLOW WARNINGS COULD RESULT IN SERIOUS INJURY OR EVEN DEATH.</b>
--	--

**DO NOT UNDER ANY CIRCUMSTANCES REMOVE ANY CAUTION, WARNING, OR OTHER DESCRIPTIVE LABELS FROM THE SYSTEM.**

# Principles of Reverse Osmosis

## How Fresh Water is Produced

Reverse Osmosis or “RO” is a process used to remove large volume of contaminants from water by forcing the fluid through a semi-permeable membrane.

## Osmosis

Osmosis is a naturally occurring process where a weak solution will cross a semipermeable membrane to mix with a highly concentrated solution. For example, a freshwater solution will naturally want to mix with a saltwater solution.

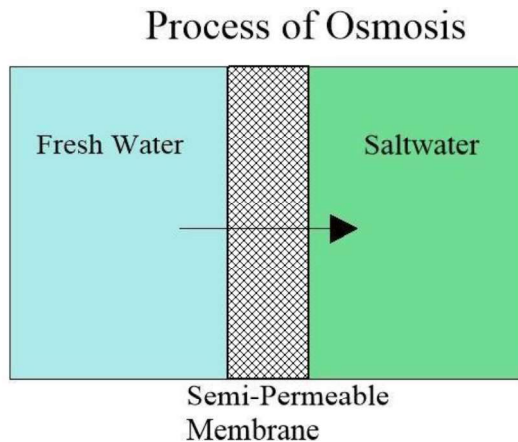

## Reverse Osmosis

To reverse this process work is put into the system using a pump. The pump causes pressure to build up on the saltwater side of the membrane. This pressure forces water across the semi- permeable membrane. The membrane is designed to allow the water molecules to pass while preventing the salt and other solids from doing so. Fresh water is collected on the other side of the membrane as a result.

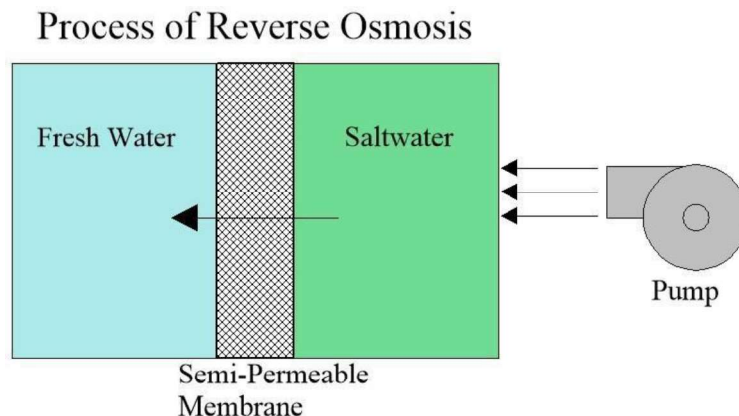

## Unit Specifications

<b>SZIII MODEL</b>	<b>2000</b>	<b>3000</b>
Configuration	1 Vessel	2 Vessels
Feed Water Source	Fresh Water	Fresh Water
Rate Production GPD(GPM)	2000 (1.39)	3000 (2.08)
<b>Rejection and Flow Rates</b>		
FW Nominal TDS Rejection % (Spot Zero)	90%	90%
Minimum Feed FlowGPM (LPM)	4.2 (15.9)	4.2 (15.9)
Minimum Concentrate Flow GPM (LPM)	1 (3.7)	1 (3.7)
<b>Connections</b>		
Feed Inch	¾" Hose	¾" Hose
Product Inch	3/8" QC 9.5mm	3/8" QC 9.5mm
Concentrate Inch	½" QC 2.7 mm	½" QC 2.7 mm
<b>Membranes</b>		
Membranes PerVessel	1	1
Membrane Quantity	1	2
Membrane Size	4041	4041
<b>Pumps</b>		
FW Pressure PumpType	Vane	Vane
FW RO Motor Amps	5.1	5.1
<b>Electrical</b>		
Voltage	115V or 230V 50/60Hz 1Φ	115V or 230V 50/60Hz 1Φ
Amp Draw	6	6
<b>System Dimensions</b>		
Width x Depth x Height inch (cm)	17.5 x 12.9 x 16.4 (44.5 x 32.8 x 41.6)	17.5 x 12.9 x 16.4 (44.5 x 32.8 x 41.6)
Weight lb. (kg)	70 (31.8)	70 (31.8)

# Installation and Commissioning



## SZIII Install Kit

✓	PART NUMBER	DESCRIPTION	QTY
	KIT0005	SZIII Install Kit	1
	J0003	Tubing, Nylon, 3/8" OD	50 ft.
	J0004	Tubing, Nylon, 0.50 in. OD	50 ft.
	B0021	Elbow 3/8" QC	4
	B0020	Elbow 1/2" QC	4
	B0019	Adapter 1/2" QC to 1/2" MNPT	2
	B0030	Adapter 3/8" QC to 1/2" MNPT	2
	D0047	TDS-EZ HANDHELD TESTER	1
	B0059	Adapter 1/2" CTS Stem to 3/8" CTS	2
	B0024	Reducer 1/2" QC Stem to 3/8" QC	2
	B0058	Adapter 5/8" QC Stem to 3/8" QC	2
	H5089	Install Kit 5/16" Hardware Set	1
	B0013	Elbow 3/8" QC Stem to 3/8" QC	4
	B0010	Elbow 1/2" QC Stem to 1/2" QC	4
	E1018	Wrench for Big Clear 4.5" #10 & #20	1
	B5001	Locking Clip, 3/8", Install Kit 20pc	1
	B5002	Locking Clip, 1/2", Install Kit 20pc	1
	H5065	Lubricant Silicone 6 grams	1
	B0043	Ball Valve 3/8" QC	1
	MN1003	SZIII Manual	1
	AE0004	Bacteriostatic Remineralizer Assembly	1
	B0048	RELEASE TOOL SET	1
	B0052	Adapter 1/2" QC Stem to 15mm QC	1
	B0053	Adapter 3/58" QC Stem to 15mm QC Stem	1
	B0054	Elbow 15mm QC	1
	B0055	Elbow 15mm QC Stem to 15mm QC	1

## System Requirements and Operation Guidelines

### Plumbing

The membranes and Freshwater RO pump used on Spot Zero™ systems require a continuous flow of water with a maximum temperature not to exceed 113°F. **Please see Complete Install Guide and the One-Line Flow Drawing on page 13 for proper plumbing of the system.**

#### CAUTION

ANY RESTRICTIONS OR BLOCKAGE IN THE CONCENTRATE LINE CAN CAUSE BACKPRESSURE, WHICH WILL INCREASE THE SYSTEM'S OPERATING PRESSURE. THIS CAN RESULT IN DAMAGE TO THE SYSTEM'S MEMBRANES AND COMPONENTS.

### Tube Cutting and Installation Procedure for Quick Connect Fittings

Cut the tube square and remove burrs and sharp edges. Ensure the outside diameter is free of scoremarks. For soft or thin-walled tube, we recommend the use of a tube insert.

Cut the tube square



Push the tube into the fitting, to the tube stop.

Push up to tube stop



Pull to check secure



#### To disconnect

Push in collet and remove tube



To disconnect, ensure the system is depressurized, push the collet square against the fitting. With the collet held in this position the tube can be removed.

## Electrical

The SZIII Series is available in single phase (1Φ) AC Current only. 115 or 230-volt models are available with a 50 or 60 Hertz option for the 230-volt unit.

Connect main power supply to main power terminal blocks. Ground main power supply and the freshwater RO pump to the grounding bus bar. Reference SZIII wiring diagram on page 12. Ensure that the electrical circuit supplying the system is compatible with the requirements of the unit and capable of supplying the specified power for the SZIII unit you are installing.

For clarification, SZIII models that have a part number of 9610003810 or 9610003807 are the 115-volt configuration, and units with a part number of 9610003808 or 9610003807 are 230-volt units.

<b>NOTE</b>	<b>IT IS RECOMMENDED THAT A QUALIFIED ELECTRICIAN WIRES YOUR SYSTEM IN ACCORDANCE WITH ALL APPLICABLE CODES, RULES, AND REGULATIONS.</b>
-------------	--

<b>⚠ WARNING</b>	<b>TO REDUCE THE RISK OF ELECTRICAL SHOCK, THE INCOMING POWER SUPPLY MUST INCLUDE A PROTECTIVE GROUND.</b>
------------------	--

### PC BOARD DIP SWITCH SETTINGS

SZIII DIP SWITCH SETTINGS			
Spot Zero Touch Screen XZ System (Boards connected together via FWSW connections)	SZ XZ	CRL X/Z	Carel Touchscreen Independent XTCII or ZTCII System (Boards not connected together via FWSW connections)
Color Graphics Touchscreen Fresh Water Board (Spot Zero)	CG FW	TXT SW	Text LCD Display Sea Water Board (Sea Exchange)

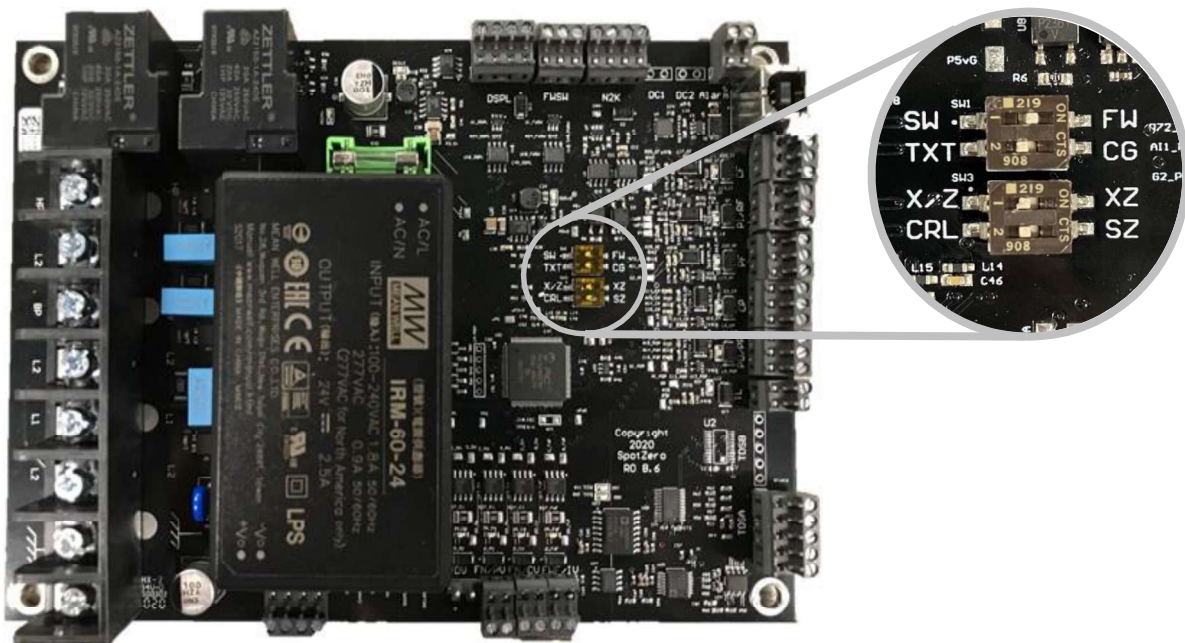

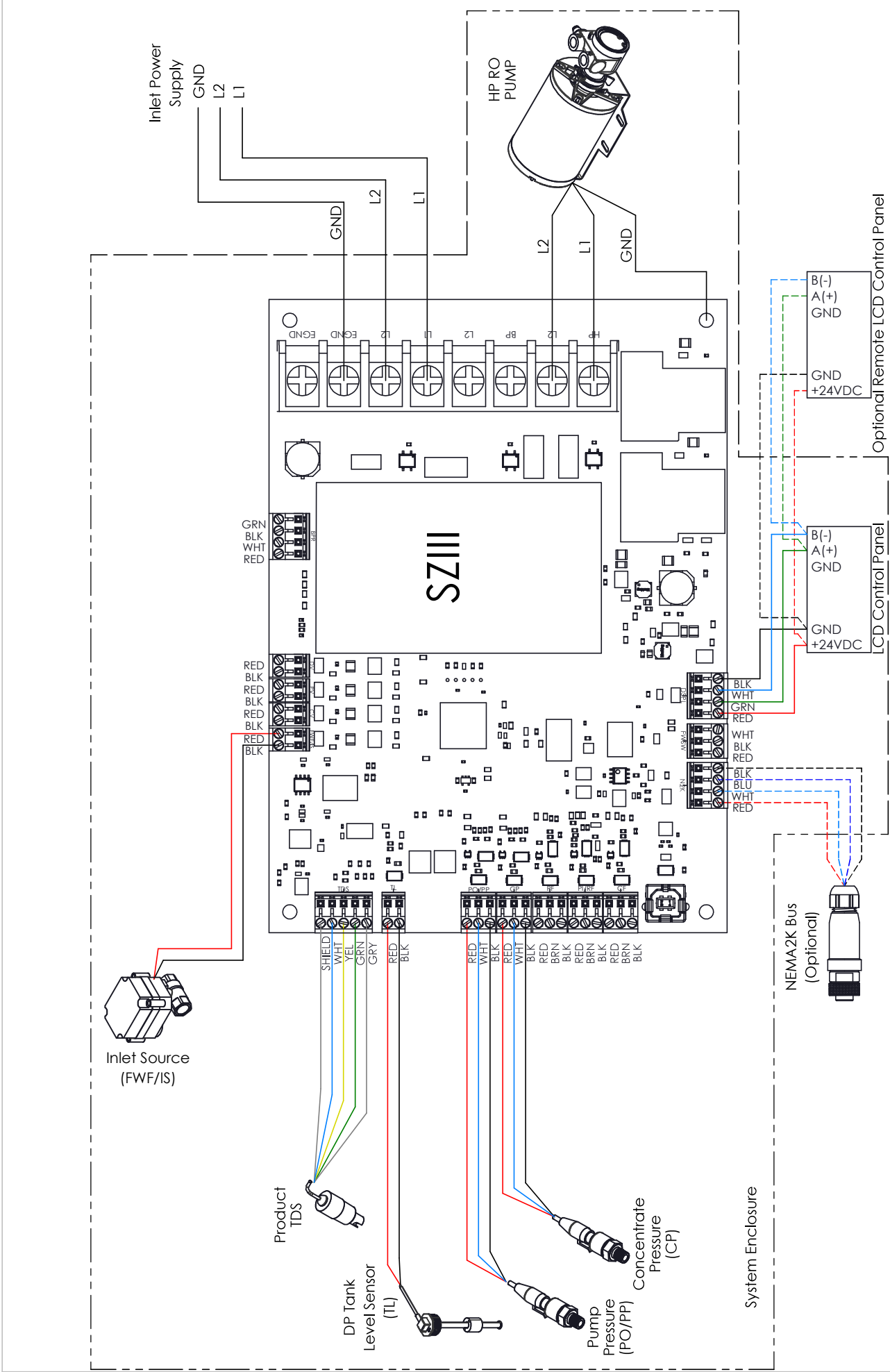

		NAME	DATE
		CT	1/18/22
DRAWN		CHECKED	ENG APPR.
SCALE: 1:1		Q.A.	MFG APPR.
DWG. NO. ED1010		SHEET 1 OF 2	
SZIII Wiring Diagram		DWG. REV A	

UNLESS OTHERWISE SPECIFIED:	
DIMENSIONS ARE IN INCHES	
OVER SIZES	
FRACTIONAL: 1/32	
ANGULAR: MACH: 1/2 BEND ±1	
TWO PLACE DECIMAL ±0.01	
THREE PLACE DECIMAL ±0.005	

**PROPRIETARY AND CONFIDENTIAL**  
 THE INFORMATION CONTAINED IN THIS DRAWING IS THE SOLE PROPERTY OF SPOT ZERO. ANY REPRODUCTION IN PART OR AS A WHOLE WITHOUT THE WRITTEN PERMISSION OF SPOT ZERO IS PROHIBITED.

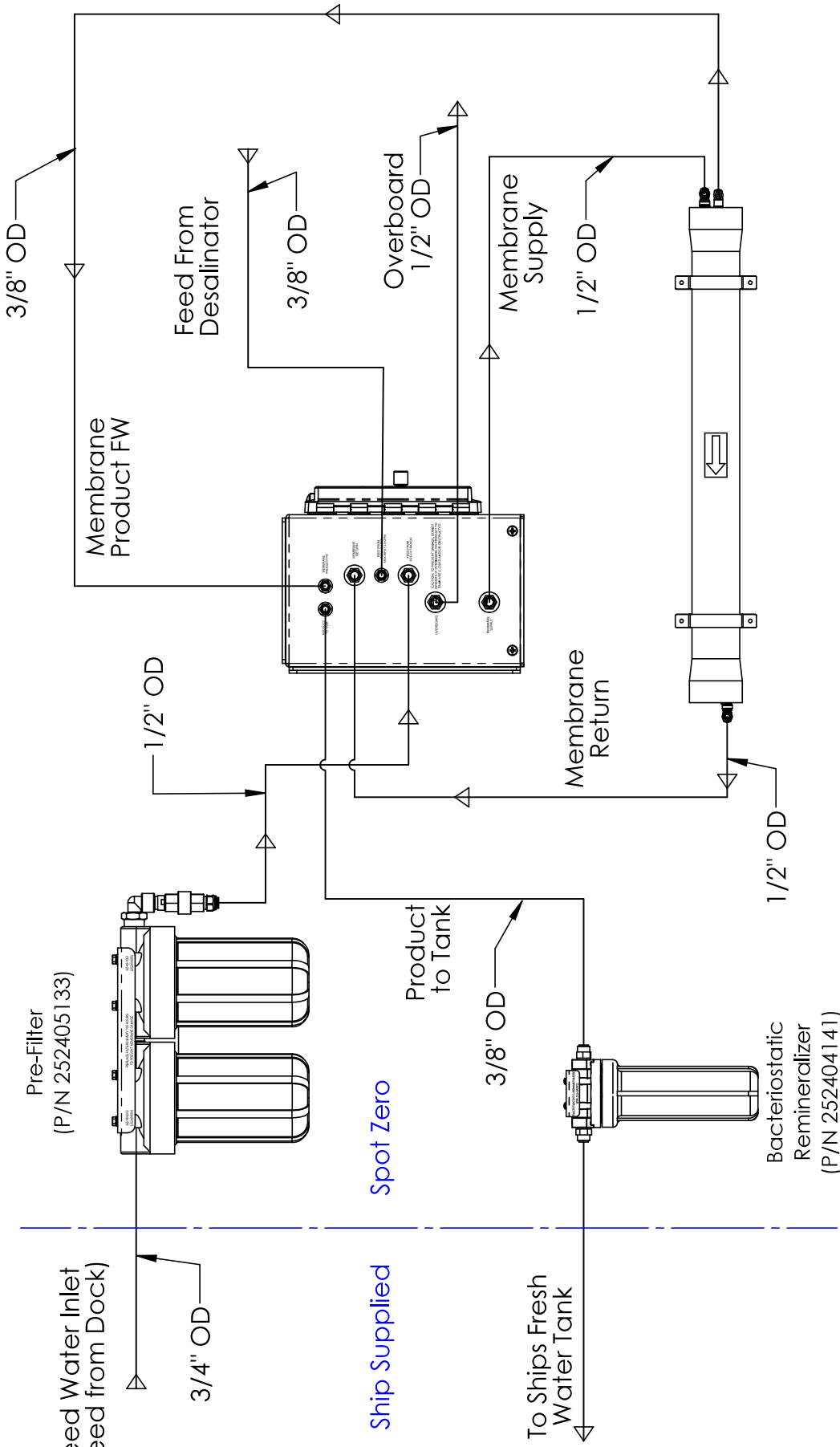

**Notes:**

- 1) The tubing or piping used for the inlet of the feed water is 3/4" I.D.
- 2) The tubing or piping used for the discharge of the concentrate is 1/2" O.D. and should be run to an open overboard in a free and unrestricted manner.
- 3) A pressure relief valve is recommended in the "Feed from Desalinator" set at 8 psi.



**SZIII One Line Flow Drawing**

NAME	DATE
CT	2/10/22
DRAWN	
CHECKED	
ENG APPR.	
MFG APPR.	
Q.A.	

UNLESS OTHERWISE SPECIFIED:  
 DIMENSIONS ARE IN INCHES  
 TOLERANCES:  
 FRACTIONAL: ±1/32  
 ANGULAR: MACH: ±1/2 BEND: ±1  
 TWO PLACE DECIMAL: ±0.01  
 THREE PLACE DECIMAL: ±0.005

**PROPRIETARY AND CONFIDENTIAL**  
 THE INFORMATION CONTAINED IN THIS DRAWING IS THE SOLE PROPERTY OF SPOT ZERO. ANY REPRODUCTION IN PART OR AS A WHOLE WITHOUT THE WRITTEN PERMISSION OF SPOT ZERO IS PROHIBITED.

## PRE-FILTRATION

The SZIII Spot Zero™ system is supplied with a standard 4.5"x10" sediment pre-filter (Part #: 252404005) that filters out most contaminants over 1 micron, and a 4.5"x10" GAC/KDF prefilter that removes chlorine, chloramine, VOCs and heavy metals (Part #: 252404004). An additional commercial-grade filter configuration is optional with a single 4.5"x20" commercial prefilter (Part #: 252404301). The standard short filters act in the same manner as the 4.5"x20" filter but are shorter in height to allow for more mounting options.

### ⚠ CAUTION

A traditional carbon block filter must not be used as it will not remove chloramines and will cause permanent membrane damage.

Prefilters should be changed every 100 hours and/or whenever there is a pressure difference of 15 psi or more between the pressure readings before and after the filter. It is imperative that the prefilters are always installed when operating the unit as the pump used in this system is susceptible to damage from sediment debris. In addition, if the prefilter becomes clogged and the water flow to the pump is reduced or interrupted, cavitation will occur and damage the pump.

### ⚠ WARNING

**SPOT ZERO SYSTEMS REQUIRE THAT THE SEDIMENT AND KDF/GAC PREFILTERS ARE INSTALLED WHILE OPERATING. RUNNING THE UNIT WITHOUT THE FILTERS WILL CAUSE DAMAGE TO THE PUMP AND WILL FOUL THE MEMBRANES.**

A Spot Zero system must be operated on filtered water only. Make sure to read all labels and instructions on the filters before installation and use.

### ⚠ CAUTION

Filter Cartridges must be flushed before installing into the system. See page 32 under the initial startup section to see how to properly flush the prefilters.

## Pre-Filtration Plumbing

Plumb the feed water from the dock into the pre-filter inlet fitting using a customer supplied 1" NPT connection. From the prefilter outlet fitting run white nylon 1/2" Spot Zero tubing to the feed from pre-filtration fitting.

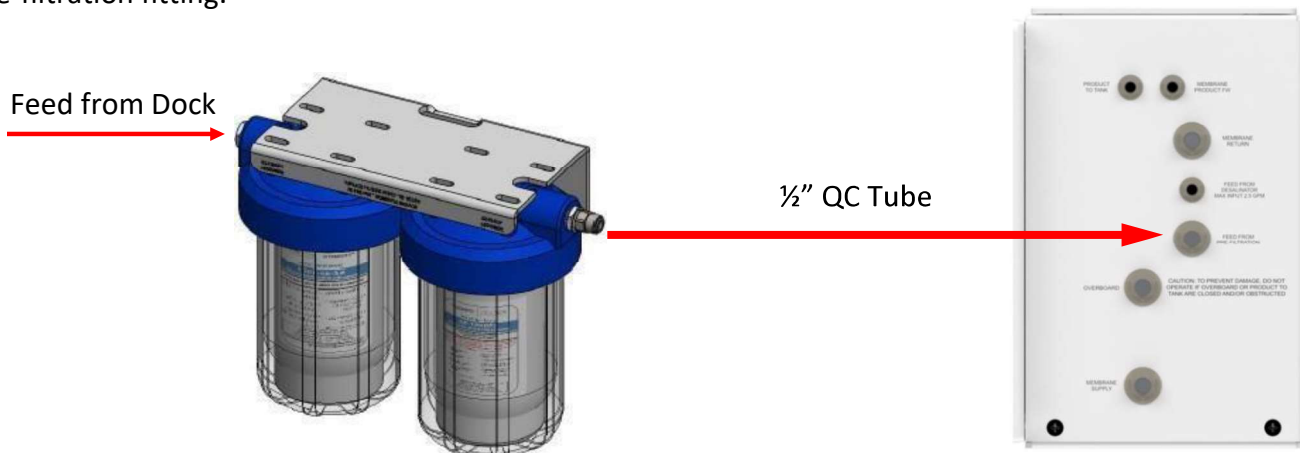

## Overboard Connection

All Spot Zero™ Systems are required to be plumbed into a ship's overboard line. For most single unit applications, a ½" QC tube may be acceptable, and should be plumbed into the dedicated overboard connection on the unit.

### **⚠ WARNING**

**SPOT ZERO SYSTEMS REQUIRE THAT THE OVERBOARD MUST NEVER BE CLOSED OR OBSTRUCTED WHILE SYSTEM IS OPERATIONAL. CLOSING OR OBSTRUCTING THE OVERBOARD FLOW ON THE SYSTEM MAY CAUSE PERMANENT DAMAGE TO THE SYSTEM.**

Locate the connection labeled "Overboard" on the left side panel of the unit. Run the supplied white ½" QC tube to a dedicated overboard connection on the ship.

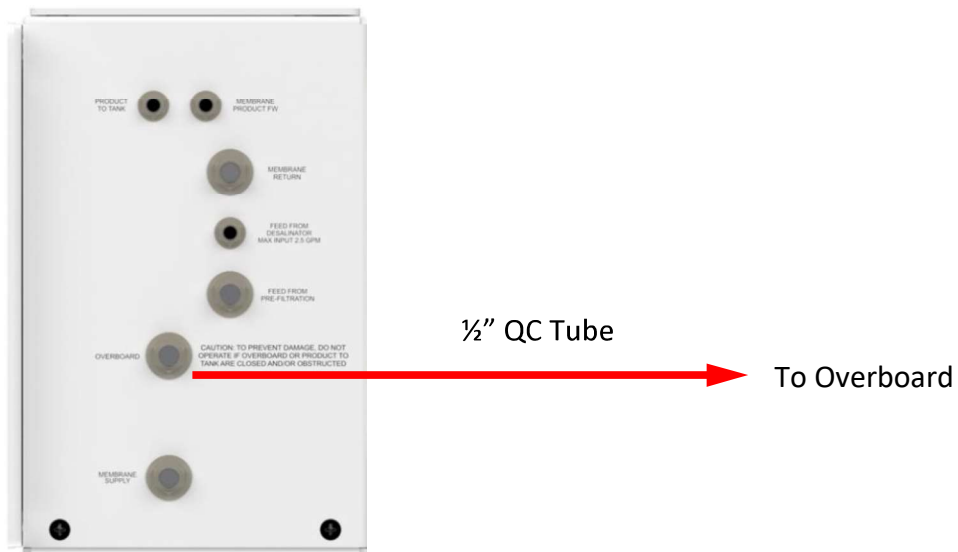

## Product to Tank Connection

It is important for the unit to be plumbed properly to the ships tank. Ensure that there are no kinks in the line and reduce the number of bends and elbows used in the hose run.

### **⚠ WARNING**

**SHIPS FRESHWATER TANK MUST BE VENTED PROPERLY TO AVOID BACK PRESSURE ON THE SYSTEM. FAILURE TO DO SO MAY CAUSE PERMANENT DAMAGE TO THE SYSTEM AND/OR RESULT IN UNDERPERFORMANCE.**

### **⚠ WARNING**

**PRODUCT TO TANK MUST NEVER BE CLOSED OR OBSTRUCTED WHILE SYSTEM IS OPERATIONAL. CLOSING OR OBSTRUCTING THE PRODUCT FLOW ON THE SYSTEM MAY CAUSE PERMANENT DAMAGE TO THE SYSTEM AND/OR RESULT IN UNDERPERFORMANCE.**

Locate the fitting labeled “Product to Tank” on the left side of the system. Connect supplied white 3/8” QC tubing from the system to the ship’s freshwater tank. If the bacteriostatic remineralizer is not going to be used then the 3/8” tubing can be ran from the unit directly to the ships tank. Please see the section on the bacteriostatic remineralizer on pg. 41 to see its purpose.

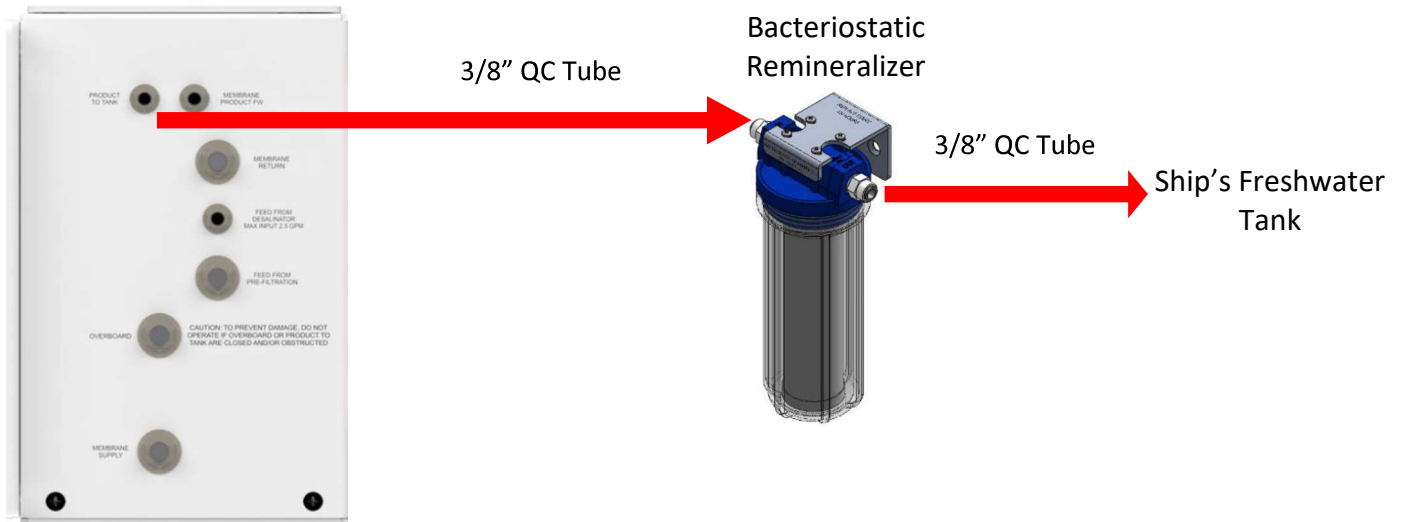

### Feed From Watermaker

Connect the 3/8” product line from the watermaker to the “FEED FROM DESALINATOR” fitting. Always install a three-way valve in line with this, so the water can be diverted to the ships fresh-water tank if required.

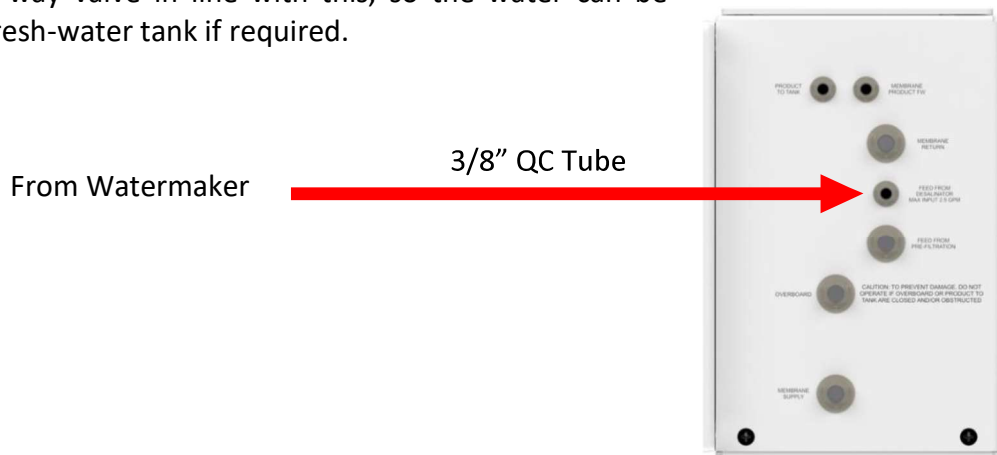

### Membrane Supply

Attach supplied 1/2” QC tubing from the “MEMRBANE SUPPLY” fitting on the unit to the “MEMBRANE SUPPLY” fitting on the membrane assemblies.

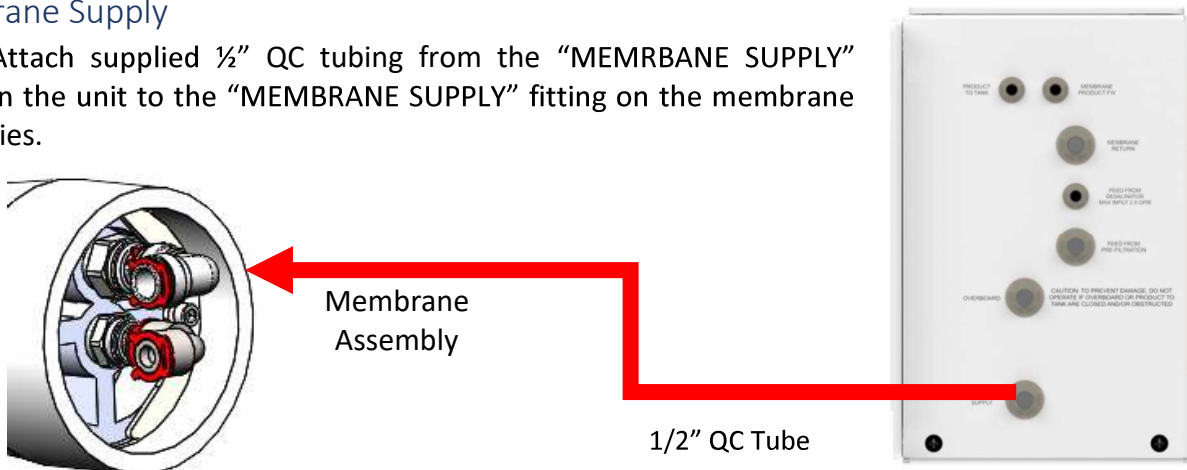



## Membrane Return

Attach supplied 1/2" tubing from the "MEMBRANE RETURN" fitting on the unit to the "MEMBRANE RETURN" fitting on the membrane assemblies.

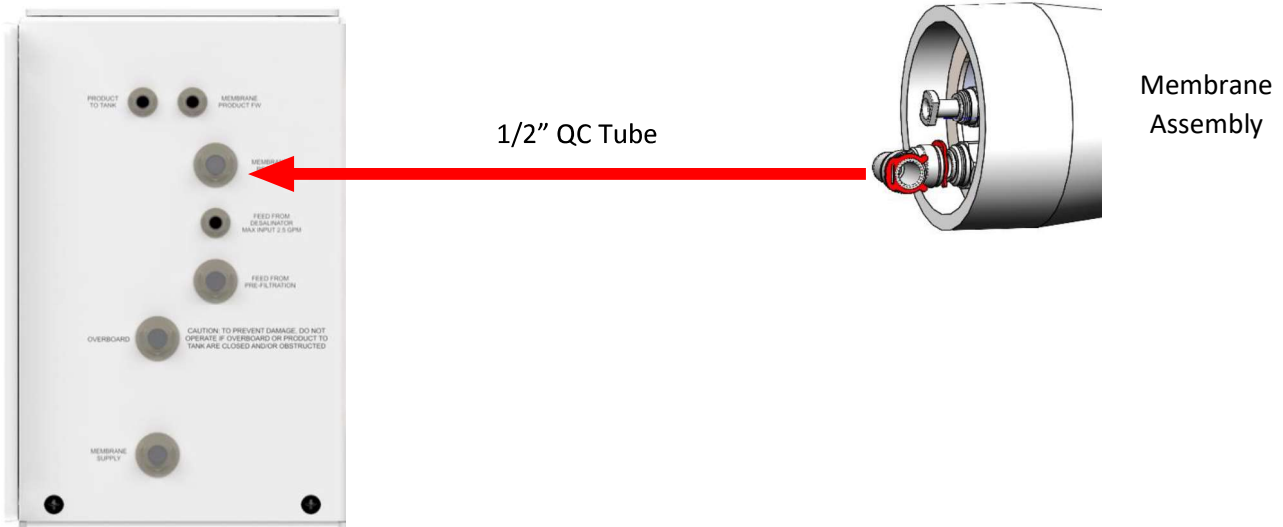

## Membrane Product

Attach supplied 3/8" tubing from the "MEMBRANE PRODUCT" fitting on the unit to the "MEMBRANE PRODUCT" fitting on the membrane assemblies. For ease of installation, the product port can be used on either side of the membrane, just remove the QC plug and flip the connection and plug.

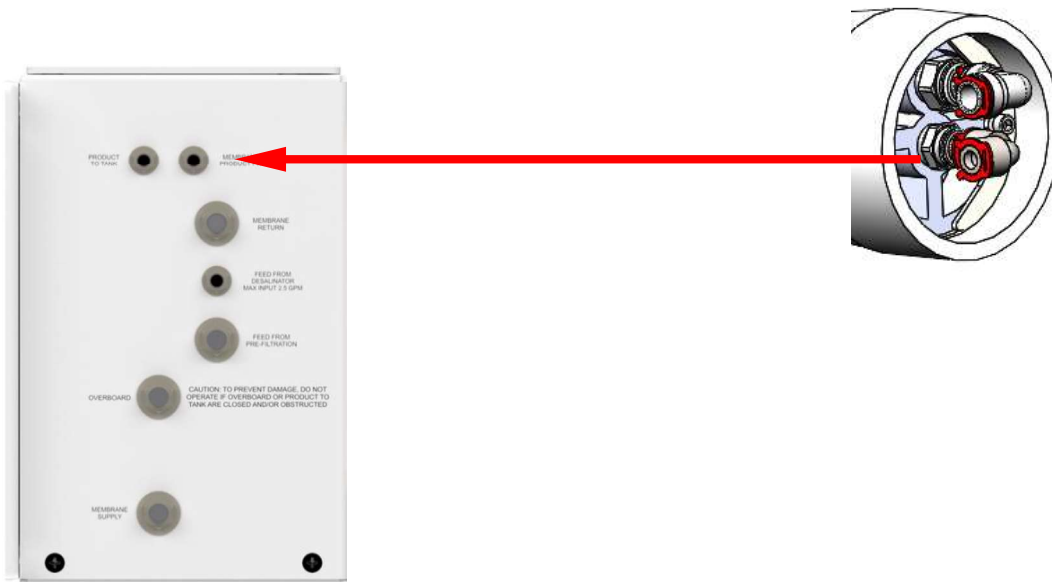

# Operation and Maintenance

## Operation Specifications

It is imperative that the operation specifications laid out in this document are followed precisely. The reverse osmosis process results in the concentration of filtered impurities and neglecting to follow the operating procedures may cause the impurities to solidify and scale or foul the membranes. To prevent this, your SZIII system should never be operated over the rated production or above the max pump pressure of **150psi**. Note that the unit will shut off if the pressure exceeds 175psi. Water temperature and inlet water ppm are variables that affect product flow and pump pressure.

### CAUTION

The rated production will have to be corrected for temperature of the inlet water when determining the rated flow of your unit. See “Temperature Correction Factors for Water Production” chart on pg. 21 for an example on correcting the rated flow rate.

### WARNING

**DO NOT OPERATE THE SYSTEM BEYOND THE RATED PRODUCTION RATE!  
DOING SO CAN CAUSE SCALING OR FOULING OF MEMBRANES.**

## Feed Water Specifications

Nothing has a greater effect on a reverse osmosis system than the feed water quality. The table below shows the maximum and minimum levels allowed for the membranes used in this system.

### NOTE

It is very important to meet the minimum feed water requirements. Failure to do so will cause the membranes to foul and result in system underperformance.

Maximum Feed Temperature °F (°C)	95 (29)	Maximum Free Chlorine ppm	0
Minimum Feed Temperature °F(°C)	40(4.4)	Maximum TDS ppm	1,000
Maximum Ambient Temperature °F(°C)	110 (43.3)	Maximum Hardness ppm	0
Minimum Ambient Temperature °F(°C)	40(4.4)	Maximum pH (Continuous)	11
Maximum Feed Pressure psi (bar)	40(5.9)	Minimum pH (Continuous)	5
Minimum Feed Pressure psi (bar)	15 (3.1)	Maximum pH (Cleaning 30 min.)	12
Maximum Operating Pressure psi (bar)	150 (10.3)	Minimum pH (Cleaning 30 min)	2
Minimum SDI Rating	<1	Maximum Turbidity NTU	1

## System Standard Operating Parameters

SYSTEMS STANDARD OPERATING PARAMETERS										
Fresh Water RO Systems	Product Flow (gpm/lpm)	Concentrate Flow (gpm/lpm)	Recycle Flow (gpm/lpm) (+/-10%)	Total Flow (gpm/lpm)	Max Pump Pressure (psi/bar)	Max Concentrate Pressure (psi/bar)	Pre-filter Inlet Minimum (psi/bar)	Pre-filter Inlet Maximum (psi/bar)	Pre-filter Outlet Pressure Minimum (psi/bar)	Pre-filter Outlet Pressure Maximum (psi/bar)
SZ/ZTCII/XZ (FW-RO) SERIES										
GPD 2000	1.4/5.3	1.0/3.8	2.0/7.6	4.4/16.7	150/10.3	150/10.3	15/1	85/4	15/1	85/4
GPD 3000	2.0/7.5	1.0/3.8	2.0/7.6	5/18.9	150/10.3	150/10.3	15/1	85/4	15/1	85/4
SZ-HD/XZ-HD (FW-RO) SERIES										
GPD 4000	2.7/10.2	1.5/5.7	2.0/7.6	6.2/23.5	150/10.3	150/10.3	15/1	85/4	15/1	85/4
GPD 5000	3.47/13.1	1.5/5.7	2.0/7.6	7.0/26.5	150/10.3	150/10.3	15/1	85/4	15/1	85/4
GPD 6000	4.16/15.7	2.0/7.6	2.0/7.6	8.2/31	150/10.3	150/10.3	15/1	85/4	15/1	85/4

Standard Parameters	
Total Dissolved Solids for Fresh Water Systems (PPM) Product Water Side	95% less than feed water
Temperature (F/C)	77/25

## Temperature Correction Factors for Membrane Production

The reverse osmosis process is also heavily dependent on the input water temperature. This is because higher temperature water has a reduced viscosity which makes it easier for the water to permeate the RO membrane. Because of this, at different temperatures the unit will either produce more or less product than its rated production at 77°F. To find the temperature correction factor (TCF) the table below may be used. Simply divide the listed standard system flow rate at 77°F by the temperature correction factor. The result is the permeate flow at the desired temperature. (See example below)

$$\text{Refence: } ^\circ\text{F} = (^\circ\text{C} \times 9/5) + 32$$

$$\text{Corrected Flow Rate} = (\text{Measured Flow Rate}) * (\text{TCF @ Feed Water Temp.})$$

### Example:

1.25 gpm @ 59° F (1.25÷1.42=.88 gpm)

1.25 gpm @ 77° F (1.25÷1=1.25 gpm)

1.25 gpm @ 84° F (1.25÷0.89=1.4 gpm)

Temperature °F (°C)	Temperature Correction Factor	Temperature °F (°C)	Temperature Correction Factor	Temperature °F (°C)	Temperature Correction Factor	Temperature °F (°C)	Temperature Correction Factor	Temperature °F (°C)	Temperature Correction Factor
50.0 (10.0)	1.711	57.2 (14.0)	1.475	64.4 (18.0)	1.276	71.6 (22.0)	1.109	78.8 (26.0)	0.971
50.2 (10.1)	1.705	57.4 (14.1)	1.469	64.6 (18.1)	1.272	71.8 (22.1)	1.105	79.0 (26.1)	0.968
50.4 (10.2)	1.698	57.6 (14.2)	1.464	64.8 (18.2)	1.267	72.0 (22.2)	1.101	79.2 (26.2)	0.965
50.5 (10.3)	1.692	57.7 (14.3)	1.459	64.9 (18.3)	1.262	72.1 (22.3)	1.097	79.3 (26.3)	0.962
50.7 (10.4)	1.686	57.9 (14.4)	1.453	65.1 (18.4)	1.258	72.3 (22.4)	1.093	79.5 (26.4)	0.959
50.9 (10.5)	1.679	58.1 (14.5)	1.448	65.3 (18.5)	1.254	72.5 (22.5)	1.090	79.7 (26.5)	0.957
51.1 (10.6)	1.673	58.3 (14.6)	1.443	65.5 (18.6)	1.249	72.7 (22.6)	1.086	79.9 (26.6)	0.954
51.3 (10.7)	1.667	58.5 (14.7)	1.437	65.7 (18.7)	1.245	72.9 (22.7)	1.082	80.1 (26.7)	0.951
51.4 (10.8)	1.660	58.6 (14.8)	1.432	65.8 (18.8)	1.240	73.0 (22.8)	1.078	80.2 (26.8)	0.948
51.6 (10.9)	1.654	58.8 (14.9)	1.427	66.0 (18.9)	1.236	73.2 (22.9)	1.075	80.4 (26.9)	0.945
51.8 (11.0)	1.648	59.0 (15.0)	1.422	66.2 (19.0)	1.232	73.4 (23.0)	1.071	80.6 (27.0)	0.943
52.0 (11.1)	1.642	59.2 (15.1)	1.417	66.4 (19.1)	1.227	73.6 (23.1)	1.067	80.8 (27.1)	0.940
52.2 (11.2)	1.636	59.4 (15.2)	1.411	66.6 (19.2)	1.223	73.8 (23.2)	1.064	81.0 (27.2)	0.937
52.3 (11.3)	1.630	59.5 (15.3)	1.406	66.7 (19.3)	1.219	73.9 (23.3)	1.060	81.1 (27.3)	0.934
52.5 (11.4)	1.624	59.7 (15.4)	1.401	66.9 (19.4)	1.214	74.1 (23.4)	1.056	81.3 (27.4)	0.932
52.7 (11.5)	1.618	59.9 (15.5)	1.396	67.1 (19.5)	1.210	74.3 (23.5)	1.053	81.5 (27.5)	0.929
52.9 (11.6)	1.611	60.1 (15.6)	1.391	67.3 (19.6)	1.206	74.5 (23.6)	1.049	81.7 (27.6)	0.926
53.1 (11.7)	1.605	60.3 (15.7)	1.386	67.5 (19.7)	1.201	74.7 (23.7)	1.045	81.9 (27.7)	0.924
53.2 (11.8)	1.600	60.4 (15.8)	1.381	67.6 (19.8)	1.197	74.8 (23.8)	1.042	82.0 (27.8)	0.921
53.4 (11.9)	1.594	60.6 (15.9)	1.376	67.8 (19.9)	1.193	75.0 (23.9)	1.038	82.2 (27.9)	0.918
53.6 (12.0)	1.588	60.8 (16.0)	1.371	68.0 (20.0)	1.189	75.2 (24.0)	1.035	82.4 (28.0)	0.915
53.8 (12.1)	1.582	61.0 (16.1)	1.366	68.2 (20.1)	1.185	75.4 (24.1)	1.031	82.6 (28.1)	0.913
54.0 (12.2)	1.576	61.2 (16.2)	1.361	68.4 (20.2)	1.180	75.6 (24.2)	1.028	82.8 (28.2)	0.910
54.1 (12.3)	1.570	61.3 (16.3)	1.356	68.5 (20.3)	1.176	75.7 (24.3)	1.024	82.9 (28.3)	0.908
54.3 (12.4)	1.564	61.5 (16.4)	1.351	68.7 (20.4)	1.172	75.9 (24.4)	1.021	83.1 (28.4)	0.905
54.5 (12.5)	1.558	61.7 (16.5)	1.347	68.9 (20.5)	1.168	76.1 (24.5)	1.017	83.3 (28.5)	0.902
54.7 (12.6)	1.553	61.9 (16.6)	1.342	69.1 (20.6)	1.164	76.3 (24.6)	1.014	83.5 (28.6)	0.900
54.9 (12.7)	1.547	62.1 (16.7)	1.337	69.3 (20.7)	1.160	76.5 (24.7)	1.010	83.7 (28.7)	0.897
55.0 (12.8)	1.541	62.2 (16.8)	1.332	69.4 (20.8)	1.156	76.6 (24.8)	1.007	83.8 (28.8)	0.894
55.2 (12.9)	1.536	62.4 (16.9)	1.327	69.6 (20.9)	1.152	76.8 (24.9)	1.003	84.0 (28.9)	0.892
55.4 (13.0)	1.530	62.6 (17.0)	1.323	69.8 (21.0)	1.148	77.0 (25.0)	1.000	84.2 (29.0)	0.889
55.6 (13.1)	1.524	62.8 (17.1)	1.318	70.0 (21.1)	1.144	77.2 (25.1)	0.997	84.4 (29.1)	0.887
55.8 (13.2)	1.519	63.0 (17.2)	1.313	70.2 (21.2)	1.140	77.4 (25.2)	0.994	84.6 (29.2)	0.884
55.9 (13.3)	1.513	63.1 (17.3)	1.308	70.3 (21.3)	1.136	77.5 (25.3)	0.991	84.7 (29.3)	0.882
56.1 (13.4)	1.508	63.3 (17.4)	1.304	70.5 (21.4)	1.132	77.7 (25.4)	0.988	84.9 (29.4)	0.879
56.3 (13.5)	1.502	63.5 (17.5)	1.299	70.7 (21.5)	1.128	77.9 (25.5)	0.985	85.1 (29.5)	0.877
56.5 (13.6)	1.496	63.7 (17.6)	1.294	70.9 (21.6)	1.124	78.1 (25.6)	0.982	85.3 (29.6)	0.874
56.7 (13.7)	1.491	63.9 (17.7)	1.290	71.1 (21.7)	1.120	78.3 (25.7)	0.979	85.5 (29.7)	0.871
56.8 (13.8)	1.486	64.0 (17.8)	1.285	71.2 (21.8)	1.116	78.4 (25.8)	0.977	85.6 (29.8)	0.869
57.0 (13.9)	1.480	64.2 (17.9)	1.281	71.4 (21.9)	1.112	78.6 (25.9)	0.974	85.8 (29.9)	0.866

## Rejection, Recovery, and Flow Rates

The Spot Zero SZIII system is designed to produce product water at the capacities indicated by the model number. For example, the SZIII-2000 produces 2000 gallons per day (1.39 gallons per minute) of permeate water at the listed operating test conditions. Meanwhile the SZIII-3000 produces 3000 gallons per day (2.08 gallons per minute) at the same test condition.

The amount of total dissolved solids (TDS) rejected by the membrane is expressed as a percentage. Spot Zero SZIII is designed to reject up to 99% of Total Dissolved Solids, meaning at best only approximately 1% of dissolved solids do not pass through the membrane. To calculate the % rejection, use the following formula.

$$\% \text{ Rejection} = [( \text{Feed TDS} - \text{Product TDS} ) / \text{Feed TDS}] \times 100$$

**Example:**

$$95\% = [(300-15)/300] \times 100$$

The amount of product water recovered for use is expressed as a percentage. To calculate the % recovery use the following formulas.

$$\% \text{ Recovery} = (\text{Product Water Flow Rate} / \text{Feed Water Flow Rate}) \times 100$$

**Example:**

$$36\% = [(1.52)/4.22] \times 100$$

**NOTE**

All TDS figures must be expressed in the same units, typically parts per million (PPM) or milligrams per liter (mg/L). All flow rates must also be expressed in the same units, typically gallons per minute or liters per minute.

## Components of the SZIII Unit

### System Controller

The controller is a logic-based PC board that can analyze and control all electrical components within the system. Its primary functions are to monitor safety thresholds of high and low pressure and perform the proper sequence of operations to optimize the start, running, and shut-down operations.

### Freshwater RO Pump

The pump used on the SZIII-series systems is a rotary vane pump constructed out of bronze.

- The pump must never be run dry. Operating the pump without sufficient feed water will damage the pump.
- Always use the required filters when operating this unit. The pump is susceptible to damage from sediment and debris.
- Refer to the pump information on Pg. 51 for further information and maintenance schedule as well as instructions on what to do if the pump fails.

### Membranes

The SZIII system comes pre-loaded with proprietary Spot Zero™ Freshwater Membranes. For best membrane performance and longevity, use only Spot Zero™ pre-filters, operate it within the pressure and flow limits, and perform scheduled flushing and maintenance when needed.

#### NOTE

Only use Spot Zero Membranes in your Spot Zero Unit. Using other membranes will cause high PPM/TDS water that will not meet system standards.

### Membrane Operation Guidelines

Avoid any abrupt pressure or crossflow variations on the spiral elements during start-up, shut-down, cleaning, or other sequences to prevent possible membrane damage. During start-up, a gradual change from a standstill to operating state is recommended as follows:

- Feed pressure should be increased gradually over a 30-60 second time frame.
- Crossflow velocity at set operating point should be achieved gradually over 15-20 seconds.
- Permeate obtained from first hour of operation should be discarded.

### Membrane General Guidelines

- Always keep elements moist after initial wetting.
- If operating limits and guidelines given in this bulletin are not strictly followed, the limited warranty will be null and void.
- To prevent biological growth during prolonged system shutdowns, it is recommended that membrane elements be immersed in a preservative solution.
- The customer is fully responsible for the effects of incompatible chemicals and lubricants on elements.
- Maximum pressure drop across an entire pressure vessel (housing) is 50 psi (3.4 bar).
- Always avoid static permeate-side backpressure.

## Membrane Replacement and Removal

Replacing membranes in the pressure vessels is an easy process if you have the proper information and tools at hand. Please refer to the following instructions when removing and replacing membrane elements:

### **⚠ WARNING**

**ALL PRESSURE GAUGES MUST READ ZERO BEFORE PROCEEDING. DISCONNECT THE POWER AND BLEED ALL WATER PRESSURE FROM THE SYSTEM.**

1. Locate the inlet end of the membrane housing, this is the side that is opposite to the flow direction.



2. Remove the two M6 x1.0x10 bolts that secure the retainer plates in place with a 5mm Allen head wrench.
3. After the bolts have been removed, remove both retainer plates by sliding them towards the center to free them from the grooved ring seat.

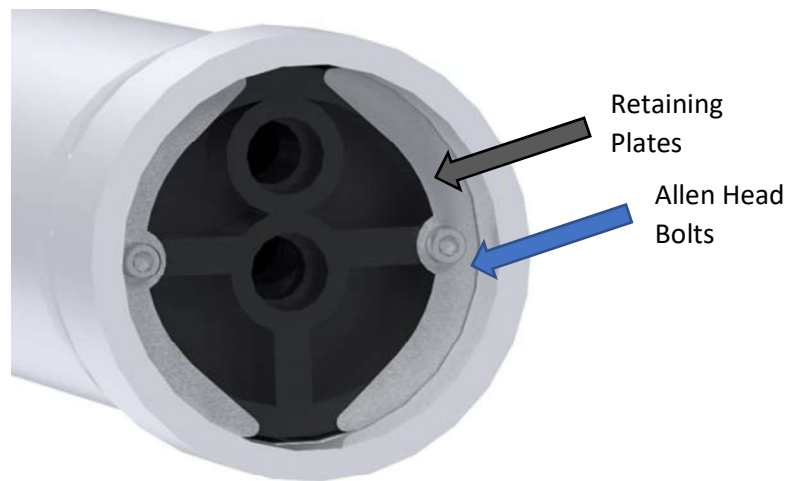

4. Remove the end hub from the pressure vessel. This may take a bit of force to do as the end hub may have come tightly pressed to the walls of the vessel. A pair of pliers may be used to pull on the hub until it is released. Upon removing set aside.





5. Slowly remove the membrane from the pressure vessel being careful not to grasp it by the permeate tube. Needle nose pliers may be necessary to pull out the old membrane element. This may take a bit of force to do as the membrane may have come tightly pressed to the walls of the vessel. Upon removing set aside. The figure below shows the proper way to grip the membranes if they cannot be removed by hand.



**CORRECT**

**INCORRECT**

**⚠ CAUTION**

Removing the membrane in the orientation shown above can only be done if you will replace it with a new membrane. If the membrane is to be reused it must be removed in the flow direction shown by the arrow. This is opposite to the direction shown in the picture above.

### Inserting the New Membrane

1. Remove the replacement membrane element(s) from the shipping box; the membrane(s) should be contained within a plastic oxygen barrier bag.

**NOTE**

Wear gloves for the following steps to not contaminate the membrane.

2. Cut the bag open as close as possible to the seal at one end of the bag, so the bag may be reused if necessary.
3. Make sure that all parts are clean and free from dirt. Examine the brine seal and permeate tube for nicks or cuts. Replace the O-rings or brine seal if damaged.
4. Lubricate the Brine Seal with a food grade lubricant. We recommend Molykote® 111 Compound.
5. Install the membrane element so the brine seal will be located at the supply side of the vessel.

**⚠ CAUTION**

The membrane can only be inserted in one direction. Installing the membrane from the wrong direction will cause the seal to not seat properly resulting in poor membrane performance. When inserting, be careful not to tear or flip the brine seal. Relubricate the brine seal if necessary.



**⚠ WARNING**

**THE BRINE SEAL MUST BE IN THE SAME POSITION FOR EACH MEMBRANE ELEMENT HOUSING. THE BRINE SEAL IS A RUBBER SEAL THAT PROTRUDES ON ONE SIDE OF THE MEMBRANE AND IS ALWAYS ON THE FEED SIDE OF THE MEMBRANE ELEMENT.**

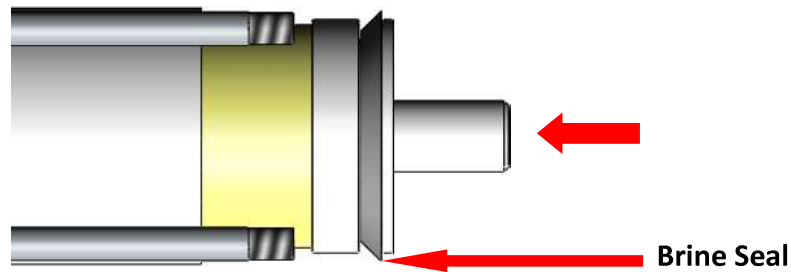

**Close up of Membrane Insertion Showing Seal Direction**

6. With a smooth and constant motion, push the membrane element into the housing so the brine seal enters the housing without coming out of the brine seal groove.
7. Re-install the end plugs by gently twisting the end cap while pushing it onto the housing.
8. Ensure that you do not pinch or fatigue any O-rings while re-installing the end plug. Push the end plug on until it is seated on the membrane and the top surface is flush with the grooved rings.
9. Reinstall the two retaining plates by pushing them in against the hub and then sliding them outwards until they seat in the grooved ring and are lined up with the tapped holes.
10. Reinstall the two M6x1.0x10 bolts that secure the retainer plates in place with a 5mm Allen head wrench.
11. Reconnect any fittings that may have been disconnected when the membrane pressure vessels were disassembled.
12. To Start-Up the system, please refer to the Initial Start-Up section of this manual on pg. 32

**⚠ CAUTION**

Wet membranes are shipped in a preservative solution. The membranes must be flushed for at least 30 minutes prior to use to remove the preservative from the membrane. Discard all the permeate and concentrate which is produced during the flush period.

**NOTE**

As time progresses, the efficiency of the membrane will be reduced. The permeate flow rate will begin to decline slightly after approximately 1000 hours of operation but can be extended with diligent flushing and cleaning of the system. A high pH and/or precipitation of hardness can cause premature loss in rejection of membrane elements in the system.

**NOTE**

To get best results from the system change the membranes every 1,000 hours.

## Preparing Unit for Storage or Shipment

### **WARNING**

**PRIOR TO SHIPPING, THE SYSTEM SHOULD BE CLEANED WITH AN APPROPRIATE CLEANER, FLUSHED WITH WATER, AND PROTECTED FROM BIOLOGICAL ATTACK WITH AN APPROPRIATE SOLUTION FOR MEMBRANE ELEMENTS. THE MEMBRANE HOUSING(S) AND PLUMBING LINES OF THE SYSTEM MUST BE COMPLETELY DRAINED. ANY WATER REMAINING IN THE PLUMBING OF A SYSTEM MAY FREEZE, RESULTING IN SERIOUS DAMAGE.**

### Preparing System for Storage:

1. If the unit will be sitting idle for a significant amount of time (i.e. anything longer than 3 months), the membrane vessels must have static water replaced with membrane storage chemical solution. The Membrane storage chemical is Part #:252404263 and can be purchased through any dealer of Spot Zero.
2. Remove the “PRODUCT TO TANK” and the “OVERBOARD” connections from the unit. Attach a sufficient length 1/2” run of LLDPE tubing into the overboard bulkhead on the unit and run this into an empty bucket. Attach a similar length 3/8” run of LLDPE tubing into the “PRODUCT TO TANK” connection and run this into the same empty bucket as the overboard.
3. Disconnect the “FEED FROM PREFILTRATION” from the unit. Attach a sufficient length 1/2” run of LLDPE tubing into the “FEED FROM PREFILTRATION” and run this into the same empty bucket as the “PRODUCT TO TANK” and “OVERBOARD”.
4. Follow the directions on the membrane storage chemical bottle to make the storage solution. This should make approximately 5 gallons of solution.
5. Pour the 5-gallon solution into the empty bucket that the “FEED FROM PREFILTRATION”, “OVERBOARD”, and “PRODUCT TO TANK” tube runs are placed in.
6. Use an auxiliary pump to circulate the solution into the unit. This pump should be hooked up into the “FEED FROM PREFILTRATION”. Once the auxiliary pump is running, turn on the system and recirculate the solution throughout the system. Complete steps 2-5 on the storage chemical bottle.
7. Be sure to plug the inlets and outlets of the system to ensure that the storage solution does not leak out of the system.

## Recommissioning the System After Storage

1. To recommission the system after the storage period, connect the “FEED FROM PREFILTRATION” tube from the filters back to the “FEED FROM PREFILTRATION” bulkhead on the unit. Reconnect the overboard connection back to the unit as well.
2. Fully open the “CONCENTRATE VALVE” by turning the handle counterclockwise. Fully close the “RECYCLE VALVE” by turning it clockwise.
3. Turn on the water supply. Once the system recognizes water flow it will begin operation. Let the unit flush for approximately 30 minutes. This is step 6 of the directions on the chemical cleaner bottle.

### **WARNING**

**ENSURE ALL OF THE PRODUCT WATER DURING THE 30 MINUTE FLUSH IS BEING DISCARDED OVERBOARD. THIS IS NON-POTABLE, HIGH PPM WATER AND COULD FOUL PLUMBING FIXTURES AS WELL AS DISCOLOR OR STAIN MATERIALS IT COMES IN CONTACT WITH.**

### **CAUTION**

Make sure to watch the product to tank bulkhead on the unit for any leaks during the flush period as this could drip on equipment or leak into the bilge.

4. After 30 minutes of flushing, power off the unit.
5. Reconnect the product to tank connection and fully open the recycle and concentrate valves by rotating counterclockwise.
6. Once the system is ready for use, the concentrate and recycle flows will have to be dialed in as instructed in the operating section.

## Winterization For Your Unit

There are two options for winterizing your unit.

### Option 1: Winterization with membrane rack removal

The best practice for winterization is to remove the membrane rack and store with Spot Zero membrane storage chemical in a heated storage climate. Information on how to store the system with the storage chemical can be found in the section above labeled “Preparing the System for Storage”. The “Feed from Desalinator” should be disconnected and the remainder of the system should be stored with propylene glycol from the dock water feed inlet to the overboard to prevent freeze damage (propylene glycol can be purchased at most hardware or automotive retailers).

### Option 2: Winterization with membrane rack

If the system is stored in freezing or near freezing temperatures and the membrane rack cannot be removed and stored in a heated climate, the following should be done.

1. Disconnect the inlet hose from the prefilter. This is the hose on the dock water side of the filter not the hose that goes from the prefilter to the unit.
2. Remove the filters from the prefilter housings.
3. Disconnect the “PRODUCT TO TANK” hose, “FEED FROM DESALINATOR”, and the “OVERBOARD” hoses from the unit.
4. Attach a short run of hose to the inlet side of the prefilters. In addition, attach a short 1/2” LLDPE hose from the “OVERBOARD” on the unit as well as a 3/8” LLDPE hose from the “PRODUCT TO TANK” on the unit.
5. A solution must be made to winterize your unit. A 5-gallon 50/50 ratio of the following two ingredients must be mixed with one bottle of the Spot Zero chemical cleaner.
  - a. Propylene glycol which can be purchased at most hardware or automotive stores
  - b. Distilled water or product water from your Spot Zero unit
  - c. Membrane storage chemical (part #252404263) which can be purchased through any dealer of Spot Zero (1 bottle)
6. Mix the contents of the Spot Zero chemical cleaner into this 5-gallon solution.

#### **⚠ WARNING**

**DO NOT USE ETHYLENE GLYCOL, ONLY NON-TOXIC PROPYLENE GLYCOL SHOULD BE USED.**

7. Place the short run of hoses that were installed in Step 4 into the 5-gallon bucket of solution created in steps 5 and 6. This should make a closed-loop flow circuit where the “INLET FEED”, “OVERBOARD” feed, and “PRODUCT” feed are all feeding/drawing from the same source.
8. Use an auxiliary pump that is plumbed directly to the prefilter. Turn the auxiliary pump on. Once the unit detects sufficient flow it will turn on. Let the system run and recirculate the solution for 15 minutes. Ensure during this time that the unit does not run dry, and air is not pumped into the system.
9. The “PREFILTRATION FEED”, “OVERBOARD”, “FEED FROM DESALINATOR”, and “PRODUCT TO TANK” should now be plugged off so none of the winterization solution leaks out of the unit as well as to prevent raw water from entering the unit.

#### **NOTE**

Process must be repeated if unit is stored for longer than 4 months.

## Recommissioning the System After Winterization

1. Reconnect the “Feed from Prefiltration” hose from the dock water inlet to the prefilter inlet. Reconnect the overboard plumbing back to the unit as well.
2. Unscrew the prefilter housing(s) and discard the winterization solution that is in the filter housing(s). Rinse the filter housing(s) with freshwater until all the solution is removed. Completely dry the filter housing(s) and insert new filter(s) into the housing. Reinstall the filter housings on the set prefilter bracket.
3. Fully open the concentrate valve by turning it counterclockwise. Fully close the recycle valve by turning it clockwise. Next, turn on the water feed to the system and then provide power to the unit. The system will turn on automatically when it detects sufficient feed water. Let the unit flush for 30 minutes, this will remove the winterization solution.

### **WARNING**

**ENSURE ALL OF THE PRODUCT WATER DURING THE 30 MINUTE FLUSH IS BEING DISCARDED OVERBOARD. THIS IS NON-POTABLE, HIGH PPM WATER AND COULD FOUL PLUMBING FIXTURES AS WELL AS DISCOLOR OR STAIN MATERIALS IT COMES IN CONTACT WITH.**

### **CAUTION**

Make sure to watch the product to tank bulkhead on the unit for any leaks during the flush period as this could drip on equipment or leak into the bilge.

4. After 30 minutes of flushing, power off the unit. Hook up the “Product to Tank” connection, the “Feed from Desalinator” and reset the recycle and concentrate valves to their normal operating positions. The unit is now ready for operation.

## Remote LCD Keypad Setup

Another LCD display may be wired to the unit if a remote screen is desired in a separate location from the unit. This display will act and function in the same manner as the master screen on the unit. Contact your Spot Zero dealer to purchase a remote LCD display assembly.

To wire up a remote screen follow the procedure below.

1. Mount the remote keypad assembly in the desired location.
2. Run the supplied four wire cable for the remote screen from the mounting location to the unit.
3. Make sure that the unit is off and disconnected from the power source
4. The front cover of the unit’s electrical box will have to be opened and the wires will need to be hooked up to the PC board on the unit. Consult the wiring diagram of the unit on pg. 12 to see the location of the connectors. They will have to be inserted into the same pin connector as the current display is using.

### **CAUTION**

To reduce the risk of electrical shock. Ensure that the unit is off, and the power is disconnected when attempting to do electrical work on the system.

5. Once the connection has been made on the local display for the SZIII unit and on the remote display the system should be ready for use. As a final check, make sure to check for loose connections that could cause intermittent grounding or sparking.
6. Reconnect the system to power and operate the system. Either display can now be used to navigate the systems interface and to see pressure, ppm and other operating parameters.

## SZIII Consumable Items

ITEM NUMBER		DESCRIPTION	MAINTENANCE FREQUENCY
252404301		Freshwater Double Stack Pre-Filter (Sediment + KDF) 4.5"x20"	Every 100 Hours
252404005		Spot Zero Sediment Pre-Filter 4.5"x10"	Every 100 Hours
252404004		Spot Zero Heavy Metal Removal (KDF) 4.5"x10"	Every 100 Hours
252404141		Bacteriostatic Remineralizer Cartridge 2.5"x10"	Every 100 Hours
252404006		Spot Zero Chemical Cleaning Cartridge 4.5"x10"	As needed when production becomes reduced
252404448		Spot Zero Freshwater Membrane Replacement for 4041 Housing	Every 1,000 Hours or 100,000 Gallons of Use

## Operating Do's and Don'ts

### **DO:**

1. Change the cartridge filters regularly
2. Monitor the system and keep a daily log
3. Adjust the system product to the recommended value
4. Always feed the pump with filtered water

### **DON'T:**

1. Permit chlorine to be present in the feed water
2. Shut down the system for extended periods of time without preservation
3. Close the pressure valves completely
4. Operate the system with insufficient feed flow
5. Operate the pump dry

## Initial Startup

Carefully inspect your system before initial start-up. Check that all plumbing and electrical connections are not loose or have not come undone during shipment. A User's Manual, Test Results, and Filter Housing Wrench will accompany your SZIII-Series Reverse Osmosis System.

1. Maintain the permeate water line (Product to Tank) to drain for this procedure.
2. Flush the provided 252404301 filter cartridges, then install into the housing. Be sure to flush outside of the system to prevent carbon dust from fouling the membranes. See the figures below on how to properly flush the filters.

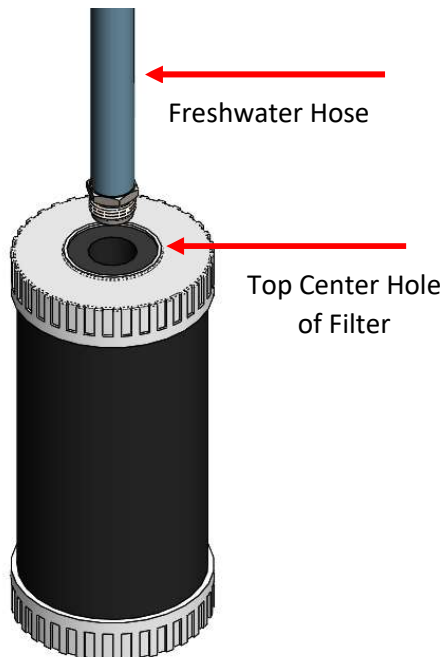

Proper Way to Flush 252404004



Proper Way to Flush 252404301

### **NOTE**

If you are using the short double pre-filters (part number 252404004 and 252404005) there will be two filter housings that are used. Only 252404004 needs to be flushed before inserting it into the housing.



3. Fully open the concentrate valve (Turn Counterclockwise)
4. Fully open the recycle valve (Turn Counterclockwise)



5. Turn the feed water on.
6. The system will automatically turn on when water flow is recognized. Allow the system to purge until no visible bubbles appear in the concentrate flow meter.
7. Check system for any leaks that may be present.

## LCD Touchpad Navigation

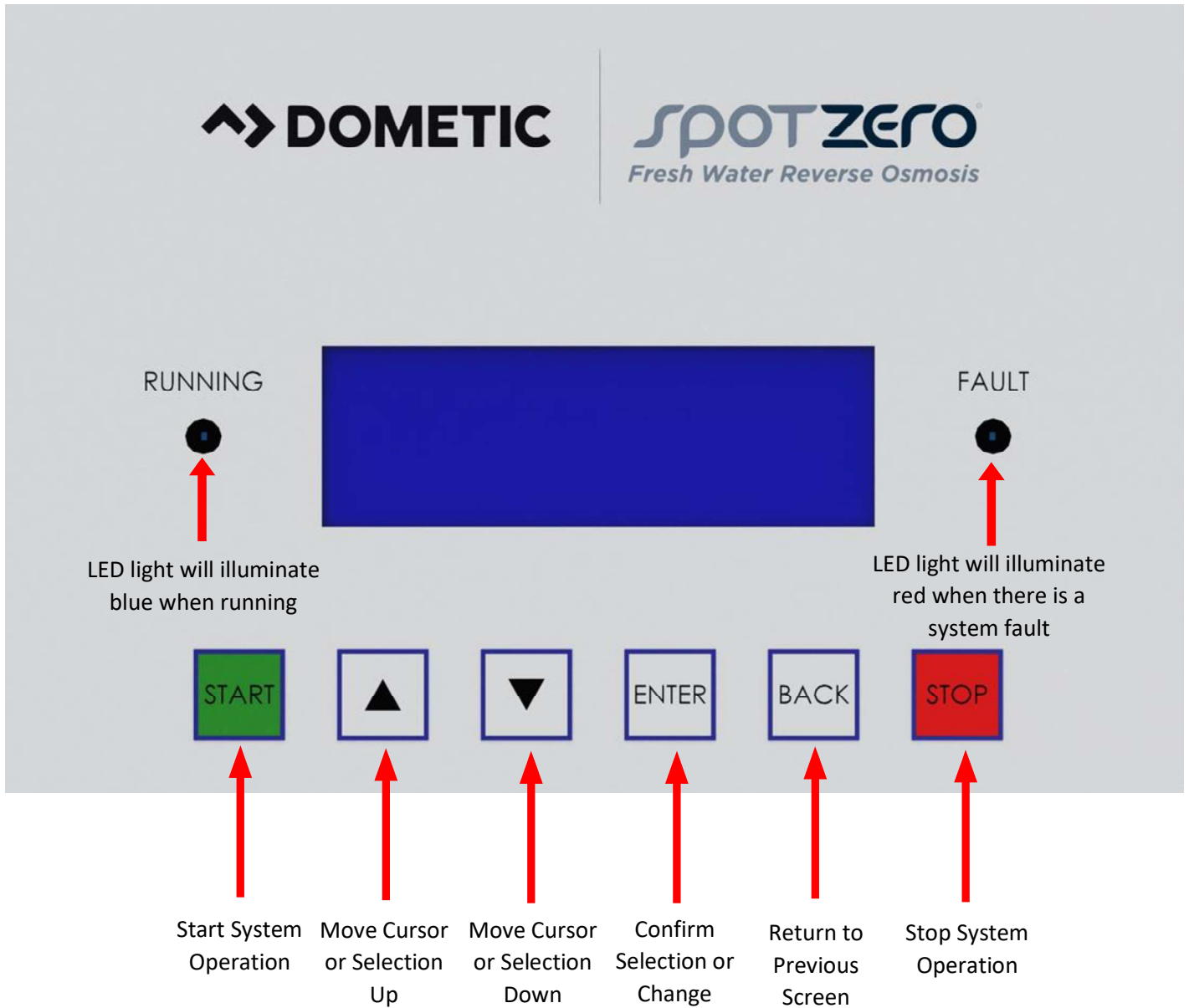

**NOTE**

START Button NOT REQUIRED for standard system operation. System will turn on when sufficient feed flow recognized.

**NOTE**

Pressing START will resume normal operation of the system if the stop button has been pressed and there is sufficient feed flow.

**NOTE**

Pressing STOP button will halt all system operation until power is cycled to the unit or the START button is pressed when proper feed flow is present.

# SZIII LCD Menu Tree

## Default Home Screens for System Operation

Standby

System Ready	76.2F
System Hrs	0.5

Running

Running	76.2 F
Pump Press	0.0 PSI
Conc Press	0.0 PSI
System Hours	0.0

Fault

System Fault	
Low Pressure	Fault
Press Enter	To Reset

### Main Menu

Press Up, Down,  
Enter or Back to  
Get to Main Menu

Summary
System Information
Input/Output
Factory Menu
Service Menu
Alarms/History

### Summary

Product TDS	15 ppm
RO Pressure	-0 psi
System Hrs	0.5
Temperature	72.3F

### System Information

Size	2000 GPD
Serial No:	00000000
FW:	v4.22 Build 1

### Input/Output

PO/PP	0.33v/	-0 PSI
CP	0.33v/	-0 PSI
PF	0.0hz/	0.00 GPM
PI/RF	1.97v/	62 PSI

CF	0.33hz/	0.0 GPM
TL	1.65v/	0.0 %
TDS		24 PPM
Temperature		72.7 F

DV	OFF
PV	OFF
CV	OFF
FWF/IS	ON

Remote Comms	OFF
N2K	Inactive
N2K Address	0
N2K Instance	9

HP	OFF
BP	OFF

SW/FW Dip	FW
TXT/CG Dip	TXT
X/Z - XZ Dip	X/Z
DisplayType	SpotZero

BPR Position	0.0
RO Pressure	-0

### Service Menu

Units of Measure	
Maintenance	
BPR Valve	
N2K Setup	

Alarms/History	0
Alarms History	

### Service Menu Breakdown

Units of Measure	FLOW	GALLONS
Pressure	PSI	
Filters(Hrs)	100	
Membrane (Hrs)	1000	
BPR Manual Initialize	No	
BPR Close	No	
BPR Open	No	
BPR Goto	77.0 %	
Current Pos	0.0 %	
N2K Setup	DI	9
	SA	0
	SI	0

## STANDARD OPERATION

1. Ensure the needle valves located on the flow meters on the front of the unit labeled “CONCENTRATE VALVE” and “RECYCLE VALVE” are fully opened (turning the knob counterclockwise until there is an increase in turning resistance).
2. Confirm all plumbing and electrical connections are properly connected and secured.
3. Power on the system, confirming the LCD display lights up, and displays the below Standby message.

### Standby

System Ready	76.2F
System Hrs	0.5

4. Starting the System
  - a. Simply turn on the feed water supply to the system and the unit will automatically detect water flow and automatically turn on. The blue LED labeled “RUNNING” should light up, indicating the system is active.

### Running

Running	77F
TDS	015 ppm
Hours	0.5

5. Making Water
  - a. Confirm the total system capacity so you know how much product water the unit should be making. After the system is operating, the “Concentrate Valve” and “Recycle Valve” will have to be adjusted to build pressure within the unit so that the system can start producing water. To build pressure, slowly turn the knob of the Concentrate Valve clockwise until you reach approximately 1.0 gpm. Turn the recycle knob clockwise until the recycle flow reaches approximately 2.0 gpm. Adjust each knob until both flow rates are achieved.
  - b. The target “Product Flow” rate for each system is shown in the table below. If after adjusting the concentrate and recycle valves the unit is still not producing the target product flow rate the pump pressure may need to be adjusted. Insert a flathead screwdriver into the hole labeled “Pressure Regulator” and turn clockwise building pressure. **Ensure that the pump pressure does not exceed 150 psi.** It is possible you may not achieve the desired production due to temperature and feed quality factors.
  - c. As pressure builds, the system will begin to produce water as indicated by the “PRODUCT” flow meter on the front of the system. Read the flow rate from the top of the metal flow indicator.
  - d. Achieve an approximate flow rate that is consistent to the rating of the system capacity per the table below.

**Rated Production numbers established at 77°F and 200ppm feedwater**

SZIII MODEL	2000	3000
Rated Production GPM	1.39	2.08

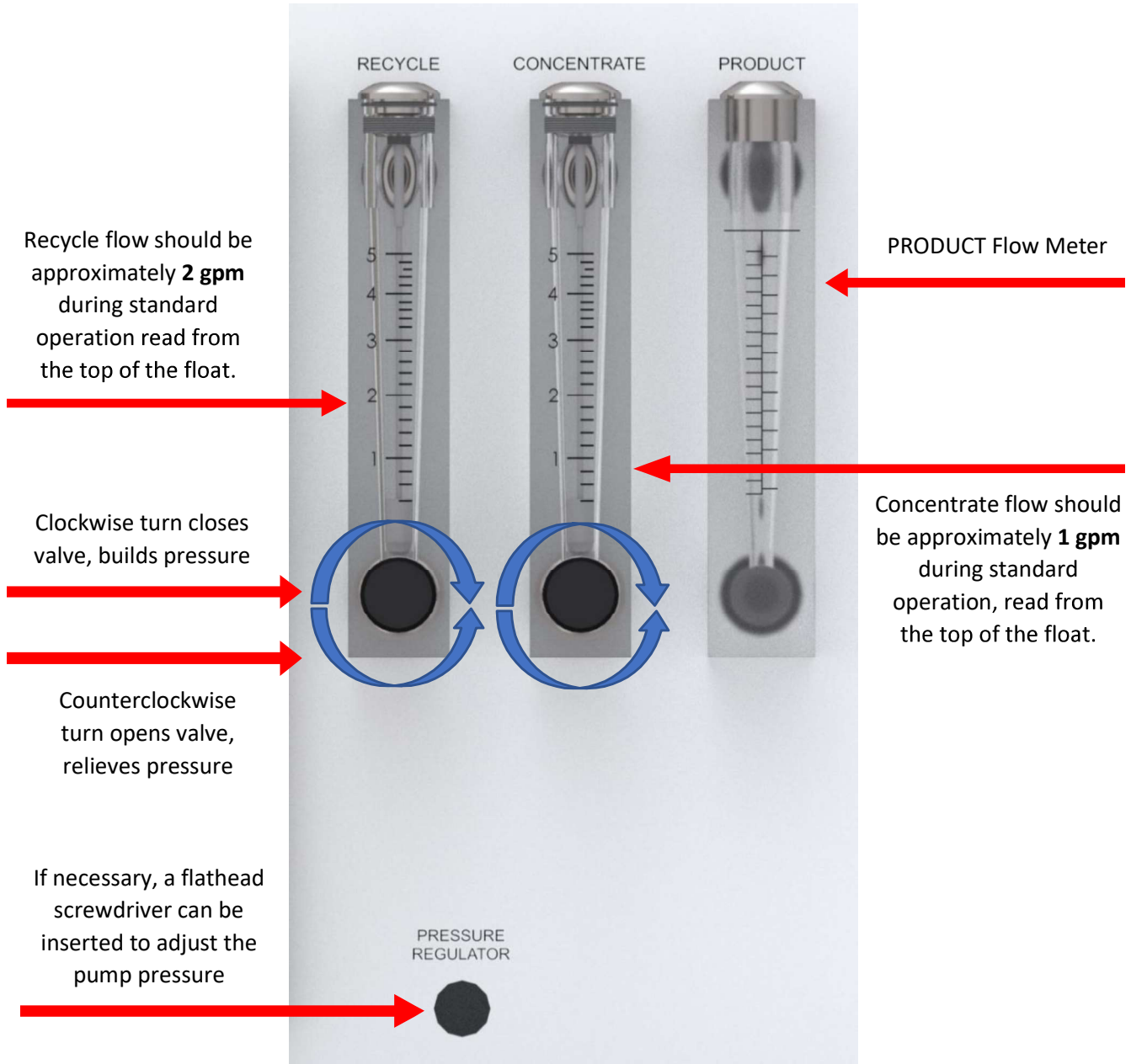

**6. System Shutdown**

- a. Turn off the supply water feed.
- b. The system will automatically shut down when it no longer detects water.
- c. To EMERGENCY STOP the system tap the red STOP button. This will turn off the system. To resume operation after an emergency stop, the unit may have to be power cycled, if pressing the start button does not turn the system back on.

## Home Screen

From any of the operating or standby home screens (ie. Standby, Running, Shutdown) press any button except for the Start or Stop buttons to navigate to the main menu shown below.

### Main Menu

The main menu is used as the primary navigation point to all system settings, parameters, and readings. To access one of the below categories, simply navigate the cursor to the desired row and press the "Enter" button.

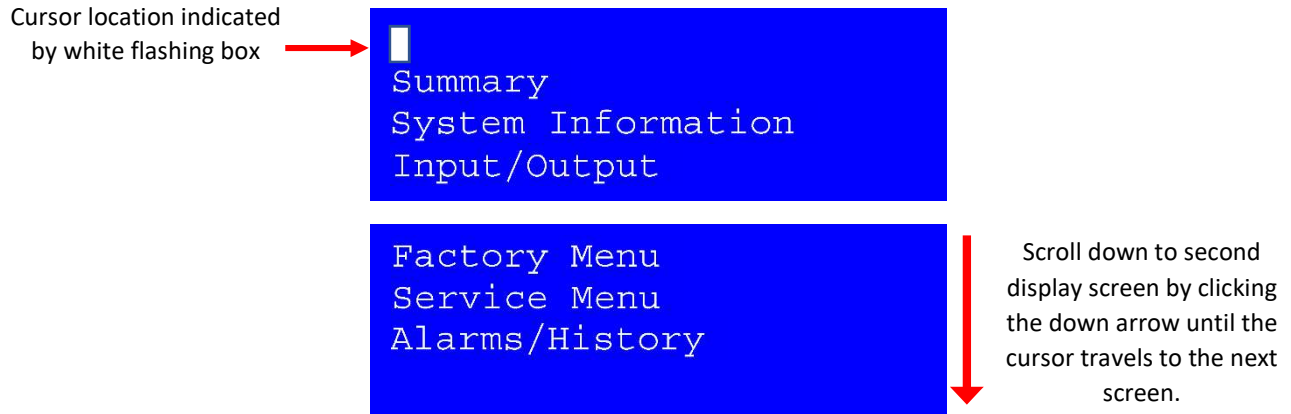

### Summary

An overview of critical system parameters is shown on the summary screen.

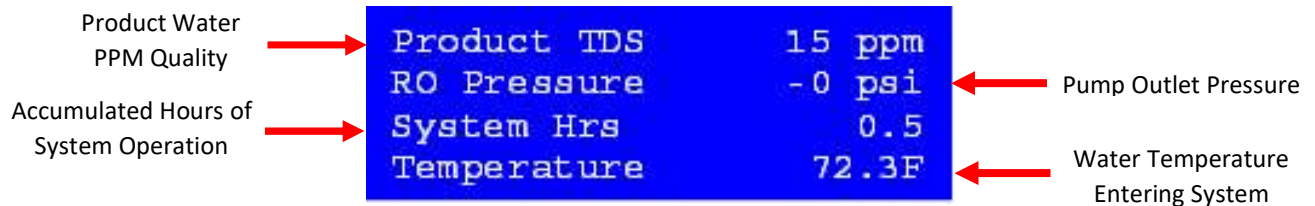

### System Information

All system information is set by the factory with appropriate information prior to customer receiving.

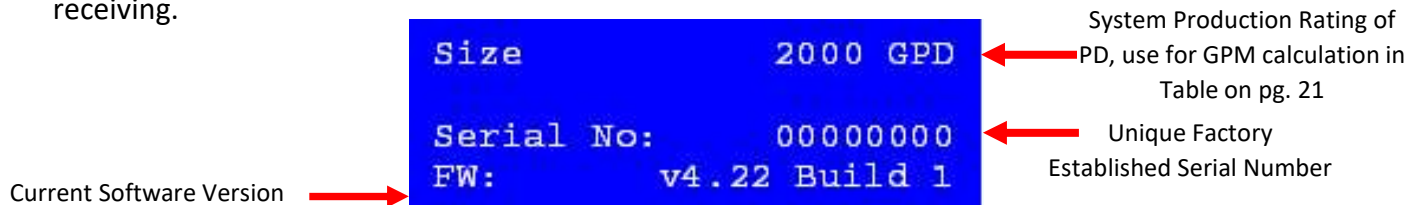

## Input/Output

Indicates which electrical components are functioning properly and what electronic signals the PC Board is receiving. There are also indication lights located on the PC Board within the electric box which should show the same information.

\*Indicates Inputs/Outputs for devices or functions not included in this system

Pre-Filter Outlet Pressure	→	PO/PP	0.35v/	1	PSI
Concentrate Pressure	→	CP	0.33v/	-2	PSI
Product Flow	→	PF	0.0hz/	0.00	GPM
Pre-Filter Inlet Pressure	→	PI/RF	0.00v/	1	PSI
*Concentrate Flowmeter	→	CF	0.33hz/	0.0	GPM
Tank Level Sensor	→	TL	1.65v/	0.0	%
TDS Salinity Probe	→	TDS		24	PPM
Temperature	→	Temperature		72.7	F
*Diversion Valve	→	DV			OFF
*Product Valve	→	PV			OFF
*Concentrate Valve	→	CV			OFF
*Freshwater Flush Valve	→	FWF/IS			ON
*Remote LCD Keypad	→	Remote Comms			OFF
NMEA Connection	→	N2K			Inactive
NMEA Address	→	N2K Address			0
NMEA Instance	→	N2K Instance			9
*High Pressure Pump	→	HP			OFF
*Boost Pump	→	BP			OFF
PC Board Dip Switch Settings	→	SW/FW Dip			FW
	→	TXT/CG Dip			TXT
	→	X/Z - XZ Dip			X/Z
	→	DisplayType			SpotZero
BPR Position Indicator	→	BPR Position			0.0
Pump Pressure	→	RO Pressure			-0

Scroll to See Other Screens

**Factory Menu**

The factory menu has multiple parameters that are established before shipping by the factory. These settings require a password to access and therefore will only be accessed when warranty or service requests are made for the system.

**Service Menu**

The service menu allows the customer to change multiple parameters to optimize the performance of their system for the functionality they desire. Before changing Service Menu settings be sure to read the appropriate section of the manual to understand the change for the desired results or contact Spot Zero Reverse Osmosis.

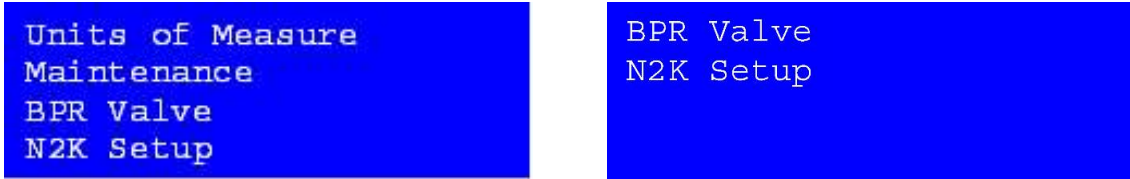

**Units of Measure**

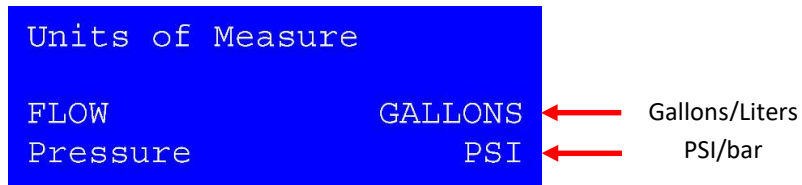

**Maintenance**

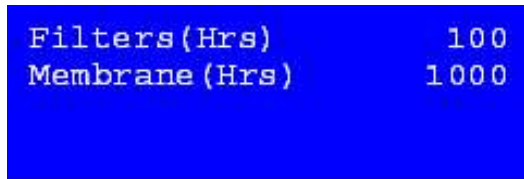

**BPR Valve**

System does not contain a BPR Valve and therefore parameter adjustment unnecessary

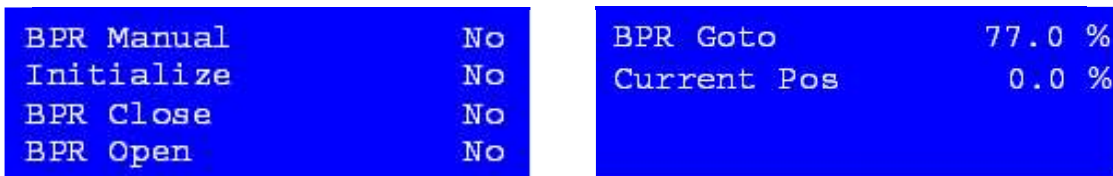

**N2K Setup**



**Alarm History**





## Performing a Freshwater Flush

Periodically the unit should be flushed with pure freshwater. This procedure helps to clean the membrane(s) of contaminants and may result in increased membrane longevity and provide better quality water over time. Skipping the freshwater flush can lead to membrane scaling and fouling at or even before the rated lifespan of 100,000 gallons for the membrane(s).

1. Turn on feed water to the system and wait for the system to turn on.
2. Fully open the concentrate valve by turning it counterclockwise. Leave the recycle flow at 2.0 gpm.
3. Allow the system to run in this setup for approximately 5 minutes.
4. After that time has elapsed, return the concentrate valve to the normal position by turning it clockwise until the flow is at 1.0 pm. The recycle valve may also have to be adjusted at this time.
5. Turn off the feedwater and allow for the system to automatically shut off.
6. Normal operation of the unit can then resume.

It is recommended that the user performs a freshwater flush on the unit after every 25-30 hours of use.

## Bacteriostatic Remineralizer

Double-pass RO water is safe for all uses in a vessel including plumbing, washing and human consumption. While this is the case, the often complicated and confusing chemistry that proves this to be the case may also dismay some customers. To combat this, Spot Zero offers a unique post-filtration device known as a Bacteriostatic Remineralizer (BR) to neutralize pH and re-mineralize the water with healthy minerals. The product water of the Spot Zero RO system simply passes through the post-filter en-route to the ship's tank. This device does not reduce pressure or flow rate of the product water by any recordable amount. Even with all the benefits provided by the Spot Zero Bacteriostatic Remineralizer, on average less than 10 ppm is added to the RO product water when passed through the Bacteriostatic Remineralizer.

### *pH Neutralization*

When the product water is sent through the BR, the few acidic ions interact with the activated carbon components of the filter. This interaction leads to bonding of the acidic H<sup>+</sup> ions with free interacting carbon compounds. The chemical bonds created, and newly introduced compounds result in a neutralization of the pH.

### *Water Remineralization*

Some customers prefer the taste of minerals in the drinking water over ultrapure water. The BR uses a unique blend of compounds to reintroduce healthy minerals that amplify taste and promote general water consumption health.

### *Bacteria Elimination*

The BR uses a filtration agent to prevent harmful bacteria from reproducing and growing within the plumbing lines onboard a vessel.

<b>NOTE</b>	The bacteriostatic remineralizer is completely optional to install. The system can be used with or without it. If the bacteriostatic remineralizer is installed it will cause slightly higher ppm levels (between 5-10 ppm increase) due to the water becoming remineralized after purification.
-------------	--

# Troubleshooting

## Troubleshooting Guide

SYMPTOMS	POSSIBLE CAUSES	CORRECTIVE ACTION
LOW PERMEATE OR LOW PRODUCT FLOW	Cold feed water	See temperature correction sheet
	Low operating pressure	Adjust throttle and concentrate valve
	Defective membrane brine seal/ Membrane installed backwards	Replace brine seal and/or reposition membranes
	Fouled or scaled membrane	Clean membranes
	Damaged product tube O-rings	Inspect and/or replace
HIGH PERMEATE OR PRODUCT FLOW	Damaged or oxidized membrane	Replace membranes
	High feed water	See temperature correction sheet
	Low operating pressure	Adjust the concentrate valve
POOR PERMEATE QUALITY	Damage product tube O-rings	Inspect and/or replace
	Damaged or oxidized membrane from Chlorine or Chloramine in feed water	Replace membrane and be sure that prefilter is changed every 100 hours
MEMBRANE FOULING	Scaling (CaSO <sub>4</sub> , CaSO <sub>3</sub> , BaSO <sub>4</sub> , SiO <sub>2</sub> )	Clean with CH-04 Chemical Cleaner. Check for overproduction
	Trapped sediment media	Replace membrane, check filtration
	Chlorine Oxidation	Check for chlorine in feed water. Be sure that the prefilter is changed every 100 hours.
SYSTEM DOES NOT TURN ON	Insufficient Power to the unit	Check for loose wires. Test Voltage to ensure proper load requirements
	Insufficient feed flow	Check for damaged or kinked lines. Ensure filter is not clogged. Check feed water flow rate
	Faulty Tank Level Sensor	Check for loose connections. Replace if necessary

### Abnormal Product Flow

As time progresses, the efficiency of the membrane will be reduced. In general, the rejection rate does not change significantly until approximately 1,000 hours after installation when operated using properly pretreated feed water. The permeate flow rate will begin to decline slightly after one year of operation but can be extended with diligent flushing and cleaning of the system. A high pH and/or precipitation of hardness can cause premature loss in rejection.

Permeate flow should be within 20% of the rated production after correcting the feed water temperatures above or below 77°F. Check your permeate flow meter to determine the permeate flow rate.

<b>NOTE</b>	To determine the temperature correction factor, locate the temperature correction table in this user manual and follow the directions on pg. 21
-------------	---

## IS MY SYSTEM WORKING PROPERLY?

### TDS REJECTION

The Spot Zero SZIII reverse osmosis system is designed to reject up to 90% of total dissolved solids (TDS). The rejection percentage is calculated by the following formula:

$$\% \text{ Rejection} = ((\text{Feed TDS} - \text{Product TDS}) / \text{Feed TDS}) * 100$$

$$\text{Example 1 :} ( (117\text{ppm} - 4\text{ppm}) / 117\text{ppm} ) * 100 = 96.58\%$$

$$\text{Example 2:} ( (900\text{ppm} - 45\text{ppm}) / 900\text{ppm} ) * 100 = 95\%$$

Both examples represent membranes in perfect operating condition. The quality of your product water will rely strictly on the feed water quality. Example 1 gives product water at 4 ppm, example 2 gives product water at 45 ppm. In both examples each system is operating at normal conditions.

### Membrane Cleaning Procedure

When membrane performance is reduced and the cause is not due to temperature or feed water quality, a membrane chemical cleaning may be required to remove scaling on the membrane film.

#### **⚠ WARNING**

**ENSURE ALL OF THE PRODUCT WATER DURING THE 30 MINUTE FLUSH IS BEING DISCARDED OVERBOARD. THIS IS NON-POTABLE, HIGH PPM WATER AND COULD FOUL PLUMBING FIXTURES AS WELL AS DISCOLOR OR STAIN MATERIALS IT COMES IN CONTACT WITH.**

#### **⚠ CAUTION**

If your unit has the double stack (252404301) filter instead of the two short prefilters (part# 252404004 & 252404005) you will need to purchase the Spot Zero chemical cleaning product (252404801) instead of the chemical cleaning cartridge (252404006). You will need to skip to the section on how to clean the membranes with the double stack filters.

#### **⚠ WARNING**

**Damage to membrane film caused by chlorine or chloramine is irreversible and cannot be corrected by chemical cleaning.**

## Membrane Cleaning with Two Short 4.5"x10" Prefilters

1. A cartridge of Spot Zero chemical cleaner (SZCCC) will need to be purchased it is part number 252404006.
2. Turn the System off.
3. Disconnect "Product to Tank" and discard any product made during the cleaning process.
4. Remove the filter from the second prefilter housing. (That is remove the prefilter from the filter unit that is on the outlet side of the prefilters.)
5. Insert the SZCCC cartridge into the filter housing removed in step 4 and reinstall the filter housing now that the SZCCC cartridge is installed.

### CAUTION

It is imperative that the KDF filter is installed before the SZCCC so that it can filter the feedwater before it comes into contact with the system. Running the unit with the KDF filter removed will cause damage.

6. Turn the feed water supply on so the unit starts. When the product ppm reading spikes, press emergency stop. Then turn the feed water supply off.
7. Allow membranes to soak for 2 hours. For heavily scaled membranes you may need to soak for up to 24 hours.
8. After 2-24 hours soak time. Remove and discard the SZCCC filter cartridge from the filter housing and reinstall filter SZ-45-1001 (252404004) back into the housing.
9. Turn the feed water back on and open the concentrate valve fully to allow the system to flush for 30 minutes
10. After 30 minutes reconnect the product to tank line and return the system to normal operating parameters.

## Membrane Cleaning with 4.5"x20" Double Stack Prefilter

1. A bottle of Spot Zero chemical cleaning product will be needed. Its part number is 252404801 and can be purchased through any dealer.
2. Turn the system off.
3. Disconnect "Product to Tank" and discard any product during the cleaning process.
4. Remove the double stack filter 252404301 from the prefilter housing.
5. There should be some water left in the bottom of the double stack prefilter once the filter is removed. Stir in the contents of the chemical cleaner into the filter housing.
6. Reinstall the double stack filter and screw the filter back into the filter base.
7. Turn the feed water supply on to the unit and allow the system to run for two minutes.
8. Turn feed water supply off so the unit shuts off. This will allow the membranes to be immersed in the chemical cleaner. Let the membranes soak for 2 to 24 hours depending on the severity of the fouled membrane.
9. After soaking open the concentrate valve fully on the unit. Turn on the feed water and let the unit run for 30 minutes. This will flush out the chemical cleaner.
10. After the system is flushed reconnect the product to tank and return the system to normal operating parameters.

## SZIII System Specification and Parts

BOM TABLE

ITEM NO.	SZ PART NUMBER	PART NUMBER	DESCRIPTION	QTY.
1	E1014	E1014	2.5X10 BLUE/CLEAR HOUSING W/O PR 1/2"	1
2	C00065	U1028-02	BACTERIOSTATIC REMINERALIZER BRACKET	1
3	E2001	E2001	NSF CARBON BLOCK FILTER, 2.5"X10", 5 MICRON	1
4	B0030	PI011224S	ADAPTER 3/8" QC TO 1/2" MNPT	2
5	H0024	91735A242	BOLT PAN HEAD 10-24 X 0.5 PHILLIPS 316 SS	4
6	E3026	151121	O RING FOR 2.5"X10" CLEAR HOUSING	1

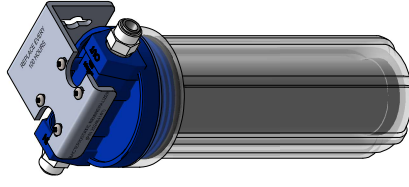
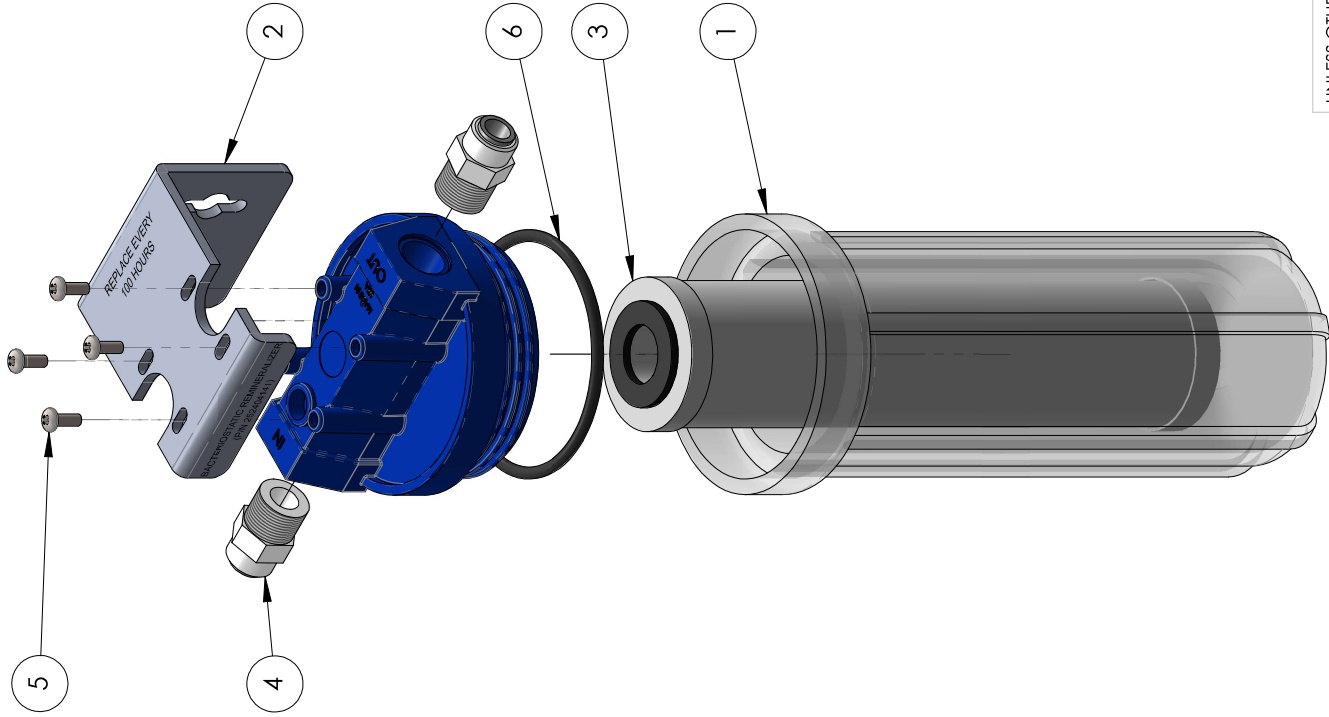

SZ P/N: AE0004rev01  
ENGINEERING P/N: GA0003-02



Bacteriostatic Remineralizer Assy

NAME	DATE
JD	6/7/2021

UNLESS OTHERWISE SPECIFIED:  
DIMENSIONS ARE IN INCHES  
TOLERANCES:  
FRACTIONAL: ±1/32  
ANGULAR: MACH ±1/2 BEND ±1  
TWO PLACE DECIMAL ±0.01  
THREE PLACE DECIMAL ±0.005

PROPRIETARY AND CONFIDENTIAL  
THE INFORMATION CONTAINED IN THIS DRAWING IS THE SOLE PROPERTY OF SPOT ZERO. ANY  
REPRODUCTION IN PART OR AS A WHOLE WITHOUT THE WRITTEN PERMISSION OF SPOT ZERO IS  
PROHIBITED.

DWG. NO. AE0004

SCALE: 1:3

SHEET 1 OF 17

DWG. REV 01

**BOM TABLE**

ITEM NO.	PART NUMBER	DESCRIPTION	QTY.
1	252404026	3/4 HP MOTOR	1
2	252404044	VANE PUMP, BRASS, 5.3GPM 1001	1
3	B0019	ADAPTER 0.5 GC TO 0.5 MNPT ACETAL	1
4	B0089	ADAPTER 0.5 CTS TO 0.5 MNPT	1

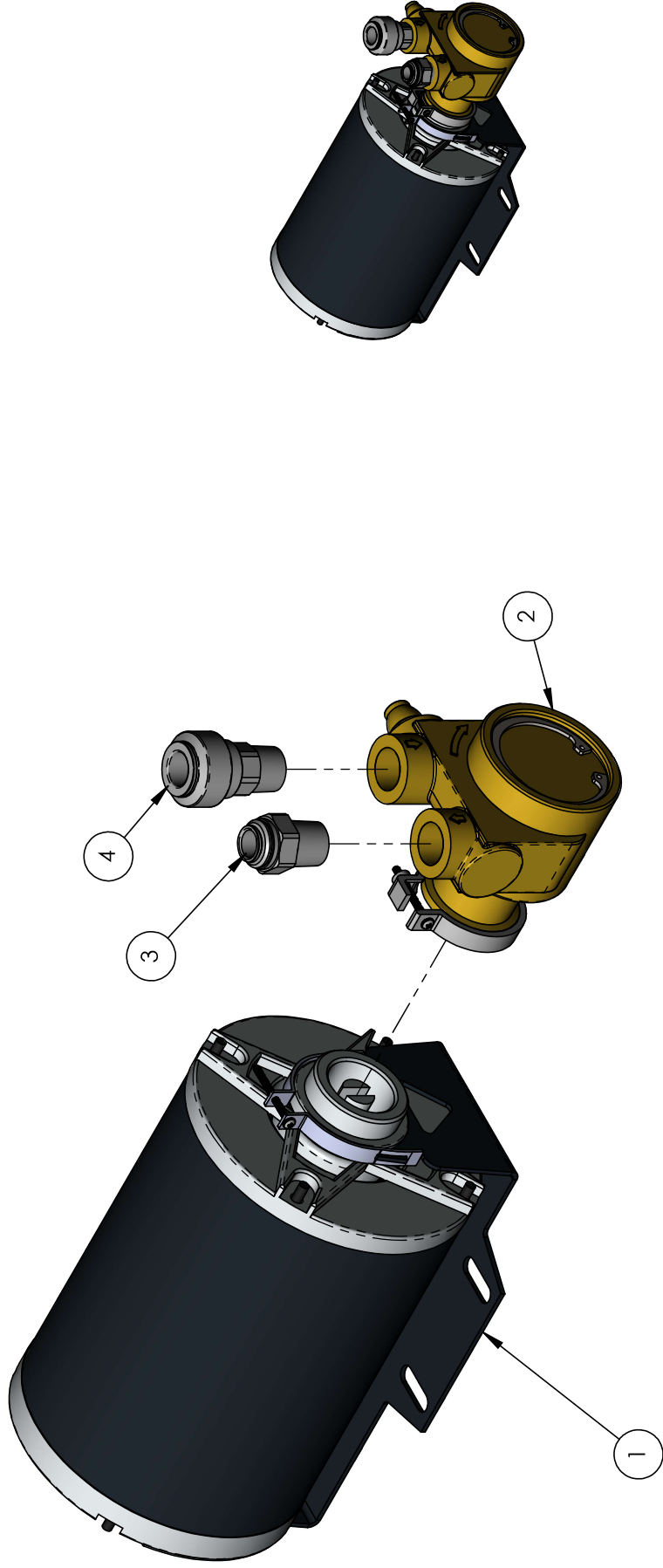

SZ P/N: MP0020



**SZIII Motor Pump Assembly**

NAME	DATE
CT	2/16/22
DRAWN	
CHECKED	
ENG APPR.	
MFG APPR.	
Q.A.	

UNLESS OTHERWISE SPECIFIED:  
 DIMENSIONS ARE IN INCHES  
 TOLERANCES:  
 FRACTIONAL ±1/32  
 ANGULAR: MACH ±1/2 BEND ±1  
 TWO PLACE DECIMAL ±0.10  
 THREE PLACE DECIMAL ±0.005

**PROPRIETARY AND CONFIDENTIAL**  
 THE INFORMATION CONTAINED IN THIS DRAWING IS THE SOLE PROPERTY OF SPOT ZERO. ANY REPRODUCTION IN PART OR AS A WHOLE WITHOUT THE WRITTEN PERMISSION OF SPOT ZERO IS PROHIBITED.

SCALE: 1:3

DWG. NO. MP0020

SHEET 1 OF 8

DWG. REV A



BOM TABLE

ITEM NO.	PART NUMBER	DESCRIPTION	QTY.
1	252404391	BRACKET, SZ DOUBLE FILTER HOUSING	1
2	252404322	4.5 X 10 BLUE/CLEAR HOUSING W/ PR	2
3	252404806	316 SS WASHER FOR 5/16" SCREW SIZE, 0.344" ID, 0.75" OD	8
4	252404807	316SS SPLIT LOCK WASHER FOR 5/16" SCREW SIZE, 0.322" ID, 0.583" OD	8
5	H1029	316 SS HEX HEAD SCREW 5/16"-18 THREAD SIZE, 1" LONG	8
6	252404004	4.5" X 10" CHLORINE/CHROMINE/HEAVY METAL REMOVAL FILTER	1
7	252404005	NSF 1 MICRON SEDIMENT FILTER 4.5" X 10"	1
8	B1043	NIPPLE CLOSE 1.0 MNPT PVC SCH 80	1
9	B1029	ELBOW 1/2" MNPT TO 1/2" FNPT PP	1
10	B1042	BUSHING 1 MNPT TO 0.5 FNPT NYLON BLACK	1
11	252404214	NIPPLE CLOSE 1/2" MNPT PP	1
12	K0015	FLOW RESTRICTOR, 3.43 GPM	1
13	252404217	SPRING CHECK VALVE 1/2" FPT	1
14	252404093	MALE CONNECTOR 0.375 QC X 0.50 MNPT-CAT	1
15	252404485	FILTER FLUSH FITTING	1

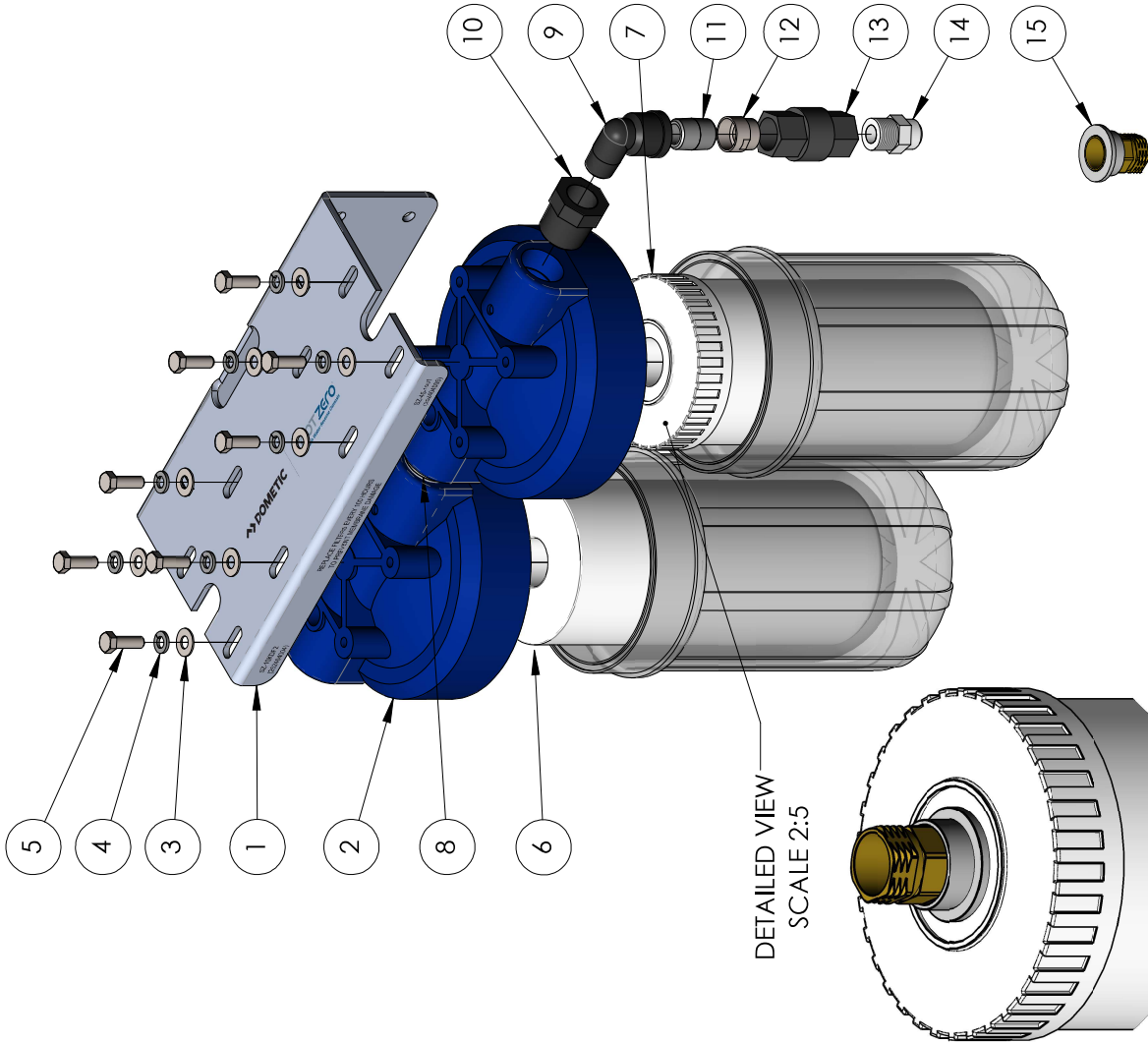

DETAILED VIEW  
SCALE 2:5

DETAILED VIEW OF FILTER  
FLUSH FITTING (#15) INSERTED INTO  
TOP OF FILTER CARTRIDGE (#6)

DRAWN	NAME	DATE
CHECKED	JD	6/7/2021
ENG APPR.		
MFG APPR.		
Q.A.		



SZIII Pre-Filter Assy. 4.5" x 10"

UNLESS OTHERWISE SPECIFIED:  
 DIMENSIONS ARE IN INCHES  
 TOLERANCES:  
 FRACTIONAL: ±1/32  
 ANGULAR: MACH ±1/2 BEND ±1  
 TWO PLACE DECIMAL ±0.01  
 THREE PLACE DECIMAL ±0.005

PROPRIETARY AND CONFIDENTIAL  
 THE INFORMATION CONTAINED IN THIS DRAWING IS THE SOLE PROPERTY OF SPOT ZERO. ANY  
 REPRODUCTION IN PART OR AS A WHOLE WITHOUT THE WRITTEN PERMISSION OF SPOT ZERO IS  
 PROHIBITED.

**BOM TABLE**

ITEM NO.	SZ PART NUMBER	PART NUMBER	DESCRIPTION	QTY.
1	AC0025	TC1009-04	SPOTZERO LARGE SINGLE FILTER BRACKET ASSY, NEW MOUNTING HOLE	1
2	E1012	252404323	4.5 X 20 BLUE/CLEAR HOUSING	1
3	H3008	90107A030	316 SS WASHER FOR 5/16" SCREW SIZE, 0.344" ID, 0.75" OD	4
4	H3013	92147A030	316SS SPLIT LOCK WASHER FOR 5/16" SCREW SIZE, 0.322" ID, 0.583" OD	4
5	H1029	93190A583	316 SS HEX HEAD SCREW 5/16"-18 THREAD SIZE, 1" LONG	4
6	B1040	5372K329	ELBOW ADAPTER 3/4" HB TO 3/4" MNPT	2
7	B2008	B2008	REDUCTING BUSHING, 1" X 3/4", POLY, BLACK	2
9	E3024	E3024 4.5 O-RING FILTER HOUSING	O RING FOR 4.5 X 20 CLEAR HOUSING	1
10	E1018	207467	WRENCH FOR BIG CLEAR 4.5" FILTER	1
11	E2032	E2032	FRESH WATER DOUBLE STACK 4.5X20 PRE-FILTER	1

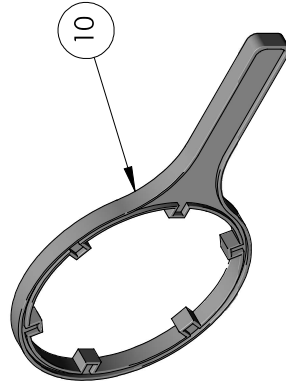
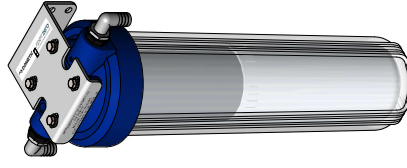
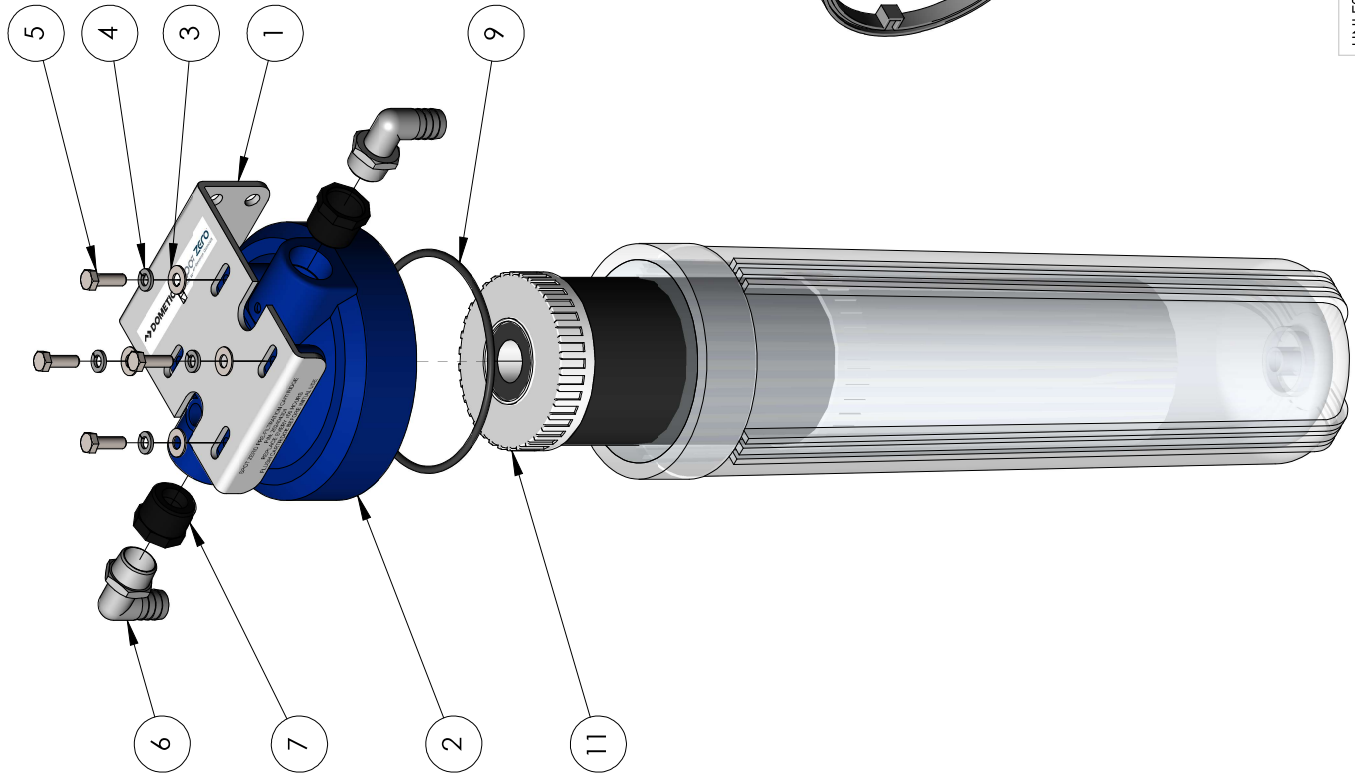

SZ P/N: E2032rev  
ENGINEERING P/N: GA0006-03



Fresh Water Double Stack 4.5"x20" Pre-Filter

NAME	DATE
JD	6/9/2021
DRAWN	
CHECKED	
ENG APPR.	
MFG APPR.	
Q.A.	

UNLESS OTHERWISE SPECIFIED:

DIMENSIONS ARE IN INCHES  
TOLERANCES:  
FRACTIONAL: ±1/32  
ANGULAR: MACH ±1/2 BEND ±1  
TWO PLACE DECIMAL ±0.10  
THREE PLACE DECIMAL ±0.005

**PROPRIETARY AND CONFIDENTIAL**  
THE INFORMATION CONTAINED IN THIS DRAWING IS THE SOLE PROPERTY OF SPOT ZERO. ANY REPRODUCTION IN PART OR AS A WHOLE WITHOUT THE WRITTEN PERMISSION OF SPOT ZERO IS PROHIBITED.

# Brass and stainless steel rotary vane pumps PO 500-1000 series

The high volume rotary vane pumps manufactured by Fluid-o-Tech® and sold worldwide under the trademark Rotoflow® are available in six flow ratings to meet the needs of high volume pumping.

## Technical features and manufacturing characteristics

The rotary vane pump with brass or stainless steel body utilizes a stainless steel AISI 303 rotor, while the pumping chamber and the vanes are in carbon graphite. Inlet and outlet ports are 1/2" GAS or NPT threaded and the pump could be equipped with a built-in adjustable relief valve. The pump can be connected to coupling direct motor with a metallic clamp or to M71 and M80 UNELMEC frame motors with the Fluid-o-Tech® coupling and adapter set. Maximum operative temperature: 70 °C (158 F)

## Available upon request:

- Viton®/EPDM seals
- Built-in relief valve
- Flange mount
- California AB 1953 compliant brass



## MAIN APPLICATIONS

- Post mix drink dispensers
- Water treatment
- Cooling systems
- Booster systems



## TECHNICAL INFORMATION

Pump housing material	Brass or stainless steel	Max static pressure	20 bar/290 psi
Pumping chamber	Carbon graphite	Pump weight	Clamp mount 1.9 kg (4.2 lb)
Ports	1/2" GAS or NPT		Flange mount 2 Kg (4.4 lb)
Speed limit	1725 rpm		

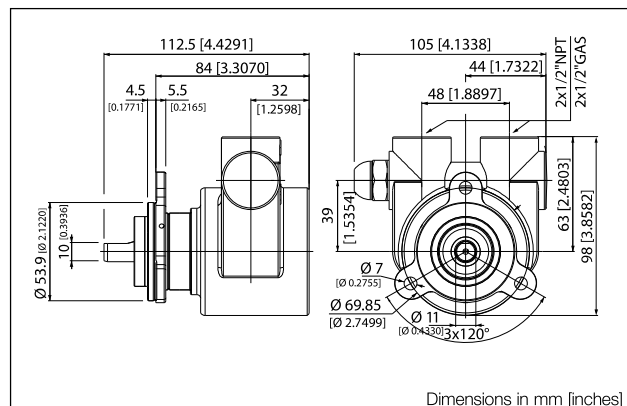
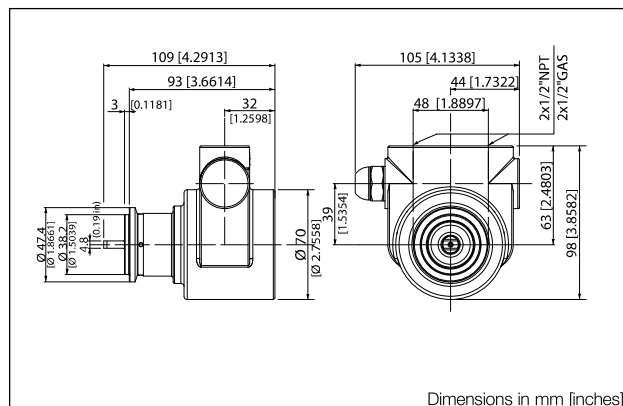

# Brass and stainless steel rotary vane pumps PO 500-1000 series

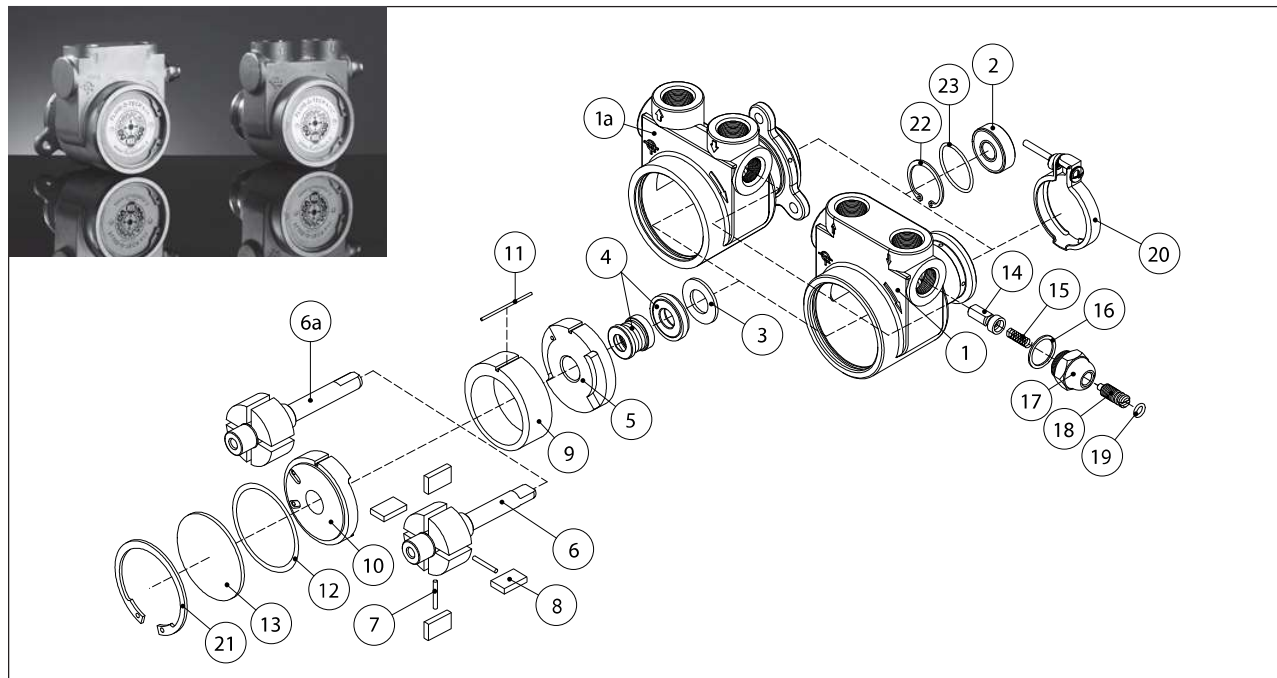

POS	DESCRIPTION	MATERIAL	CODE	NOTES
1	HOUSING WITH BYPASS	BRASS	28-01-02	NPT PORTS
		S.S.	28-01-11	NPT PORTS
1A	HOUSING WITH BYPASS AND FLANGE	BRASS	28-01-05	NPT PORTS
		S.S.	28-01-14	NPT PORTS
2	BALL BEARING	STEEL	90-22-01	
3	WASHER	S.S.	22113	
4	MECHANICAL SEAL	CERAMIC/NBR	90-40-01	NSF/WRAS
		CERAMIC/VITON®	90-40-03	
		CERAMIC/EPDM	90-40-05	
5	REAR FLANGE	GRAPHITE	28-03-04	
6	ROTOR	S.S.	28-02-01	
6A	"D" ROTOR (FLANGE)	S.S.	28-02-02	
			28-07-08	500 l/h
			28-07-09	600 l/h
			28-07-10	700 l/h
			28-07-11	800 l/h
			28-07-12	900 l/h
			28-07-13	1000 l/h
7	VANE PIN	S.S.	28-04-02	
8	VANE		28-05-10	500 l/h
			28-05-11	600 l/h
			28-05-12	700 l/h
			28-05-13	800 l/h
			28-05-14	900 l/h
9	LINER		GRAPHITE	28-05-15

POS	DESCRIPTION	MATERIAL	CODE	NOTES
10	FRONT FLANGE	GRAPHITE	28-03-06	
11	ALIGNMENT PIN	S.S.	28-07-15	
12	CAP O-RING	NBR	90-23-93	NSF/WRAS
		VITON®	90-23-95	
		EPDM	90-23-94	
13	CAP	S.S.	28015	
14	SOLID BYPASS VALVE	BRASS	22-16-02	
		S.S.	22-16-03	
		PLASTIC	22-16-15	
15	SPRING	S.S.	22505	
16	WASHER	NYLON®	22-12-01	NSF/WRAS
17	BYPASS NUT	BRASS	22-20-01	
		S.S.	22-20-04	
18	BYPASS SCREW	BRASS	28071	
		S.S.	28072	
19	BYPASS SCREW O-RING	NBR	90-23-16	NSF/WRAS
		VITON®	90-23-20	
		EPDM	90-23-24	
20	ASSEMBLED CLAMP	S.S.	94-80-01	
21	FRONT SEEGER CIRCLIP	STEEL	28016	
22	REAR SEEGER CIRCLIP	STEEL	22083	
23	O-RING	NBR	90-23-26	

Fluid-o-Tech reserves the right to alter the specifications indicated in this catalogue at any time and without prior notice.

**Fluid-o-Tech srl**  
Via Leonardo da Vinci, 40  
20094 Corsico, Milano, Italy  
Tel. +39 02 9995 01  
Fax +39 02 9995 0999  
info@fluidotech.it

**Fluid-o-Tech Int'l Inc.**  
161 Atwater St.,  
06479 Plantsville CT (USA)  
Tel. +1 (860) 276 9270  
Fax +1 (860) 620 0193  
info@fluid-o-tech.com

**Fluid-o-Tech Int'l Inc. Japan**  
201, 4-3-10, Todoroki,  
Setagaya, Tokyo 158-082, Japan  
Tel. +81 (0) (3) 6432 1812  
Fax +81 (0) (3) 6432 1813  
erkkato@fluidotech.jp

**Fluid-o-Tech Asia (Shanghai) Co., Ltd.**  
2/F, Factory building 6 (1), No. 258, Zhijiang Road,  
Fengxian District, Shanghai City, Z.P.: 201499 China  
Tel. +86 (021) 67100 838  
Fax +86 (021) 67100 605  
info@fluidotech-asia.com

# Brass and stainless steel rotary vane pumps PO 500-1000 series

Model PO/PA/PW Brass	500	501	500F	501F	600	601	600F	601F	700	701	700F	701F	800	801	800F	801F	900	901	900F	901F	1000	1001	1000F	1001F						
Model PO/PA/PW Stainless Steel	510	511	510F	511F	610	611	610F	611F	710	711	710F	711F	810	811	810F	811F	910	911	910F	911F	1010	1011	1010F	1011F						
Figure		L-L					M-M					N-N					P-P					R-R					S-S			
Relief valve	NO	YES	NO	YES	NO	YES	NO	YES	NO	YES	NO	YES	NO	YES	NO	YES	NO	YES	NO	YES	NO	YES	NO	YES	NO	YES				
Flange mount	NO	NO	YES	YES	NO	NO	YES	YES	NO	NO	YES	YES	NO	NO	YES	YES	NO	NO	YES	YES	NO	NO	YES	YES	NO	YES				
Clamp mount	YES	YES	NO	NO	YES	YES	NO	NO	YES	YES	NO	NO	YES	YES	NO	NO	YES	YES	NO	NO	YES	YES	NO	NO	YES					

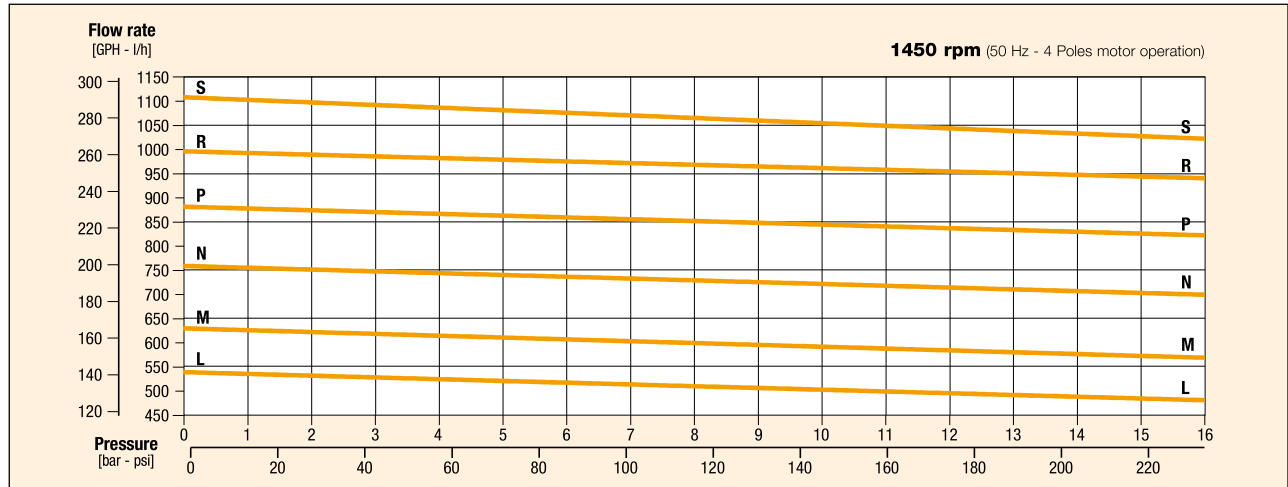

Model PO/PA/PW Brass	500	501	500F	501F	600	601	600F	601F	700	701	700F	701F	800	801	800F	801F	900	901	900F	901F	1000	1001	1000F	1001F						
Model PO/PA/PW Stainless Steel	510	511	510F	511F	610	611	610F	611F	710	711	710F	711F	810	811	810F	811F	910	911	910F	911F	1010	1011	1010F	1011F						
Figure		L'-L'					M'-M'					N'-N'					P'-P'					R'-R'					S'-S'			
Relief valve	NO	YES	NO	YES	NO	YES	NO	YES	NO	YES	NO	YES	NO	YES	NO	YES	NO	YES	NO	YES	NO	YES	NO	YES	NO	YES				
Flange mount	NO	NO	YES	YES	NO	NO	YES	YES	NO	NO	YES	YES	NO	NO	YES	YES	NO	NO	YES	YES	NO	NO	YES	YES	NO	YES				
Clamp mount	YES	YES	NO	NO	YES	YES	NO	NO	YES	YES	NO	NO	YES	YES	NO	NO	YES	YES	NO	NO	YES	YES	NO	NO	YES					

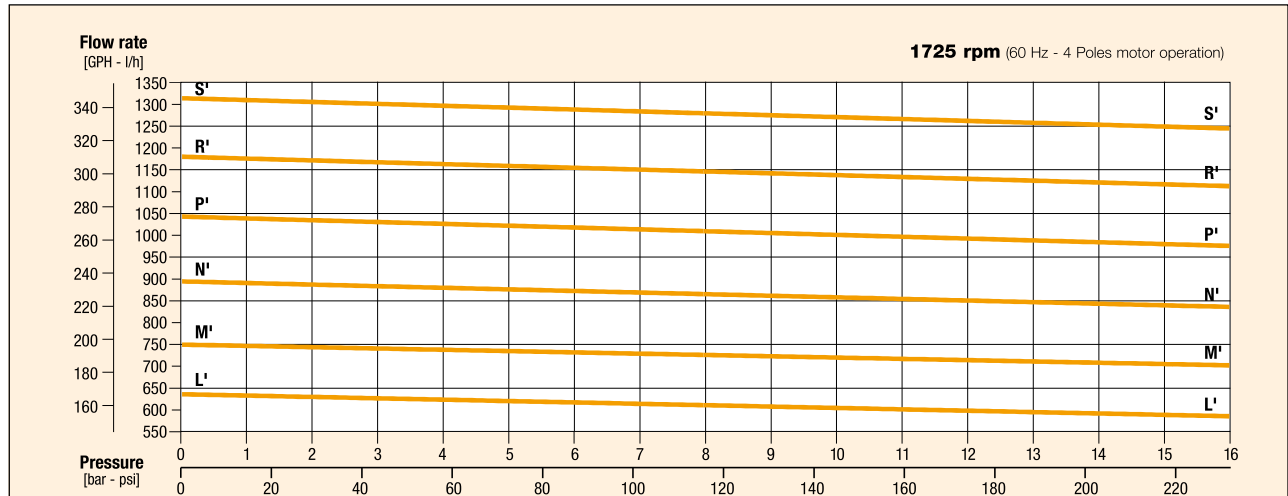

Note: Characteristics at constant motor speed, with water at 20 °C (68 F) and bypass blocked - Figures of flow are averages.  
For applications involving other fluids, high temperatures or unusual processing conditions, please consult the factory or an authorized Fluid-o-Tech distributor.

Fluid-o-Tech reserves the right to alter the specifications indicated in this catalogue at any time and without prior notice.

**Fluid-o-Tech srl**  
Via Leonardo da Vinci, 40  
20094 Corsico, Milano, Italy  
Tel. +39 02 9995 01  
Fax +39 02 9995 0999  
info@fluidotech.it

**Fluid-o-Tech Int'l Inc.**  
161 Atwater St.,  
06479 Plantsville CT (USA)  
Tel. +1 (860) 276 9270  
Fax +1 (860) 620 0193  
info@fluid-o-tech.com

**Fluid-o-Tech Int'l Inc. Japan**  
201, 4-3-10, Todoroki,  
Setagaya, Tokyo 158-082, Japan  
Tel. +81 (0) (3) 6432 1812  
Fax +81 (0) (3) 6432 1813  
erkkato@fluidotech.jp

**Fluid-o-Tech Asia (Shanghai) Co., Ltd.**  
2/F, Factory building 6 (1), No. 258, Zhijiang Road,  
Fengxian District, Shanghai City, Z.P.: 201499 China  
Tel. +86 (021) 67100 838  
Fax +86 (021) 67100 605  
info@fluidotech-asia.com

# Warranty

## OWNER'S LIMITED WARRANTY

Spot Zero warrants to the original purchaser/owner, and to subsequent owners during the applicable Limited Warranty Period, Spot Zero's Water Purification Products, Pumps, Related Accessories and Replacement Parts against failure from defects in material or workmanship arising in the periods specified in the Table of Limited Warranty Periods below. If a covered product or part fails during the applicable warranty period, Spot Zero will remedy same by repairing or replacing the defective warranted product or part as outlined below in the Table of Limited Warranty Periods. Defective parts shall be replaced free of charge and labor shall be paid for by Spot Zero only as set forth in the Table.

Spot Zero reserves the right to refund the purchase price of the subject product or part as an alternative remedy to repair or replacement. The remedy allowed hereunder (repair, replacement, or refund) shall be at Spot Zero's sole option.

### **SECTION I**

#### **WHAT'S COVERED**

##### **What does the Limited Warranty cover?**

Water Purification Products, Pumps, Related Accessories and Replacement Parts manufactured and/or marketed by Spot Zero for the durations set forth in the Table of Limited Warranty Periods.

##### **What is disclaimed, and are the warranties and remedies exclusive of all others?**

**Spot Zero does not disclaim the implied warranty of merchantability but limits the duration of that implied warranty to the duration of the Limited Warranty offered herein.**

**This Limited Warranty, as well as the implied warranty of merchantability and the remedies offered by Spot Zero herein, are EXCLUSIVE and are made or provided in lieu of all other express or implied warranties, obligations, or liabilities. In no event shall Spot Zero be responsible or liable for any incidental or consequential damages alleged to have resulted from any defect in or failure of any warranted product or part. In those instances, in which a cash refund is made, such refund shall effect the cancellation of the contract of sale and such refund shall constitute full and final satisfaction of all claims which the purchaser has or may have against Spot Zero due to any actual or alleged breach of warranty, either express or implied, including, without limitation, the implied warranty or merchantability or fitness for a particular purpose.** Some states do not allow the exclusion or limitation of incidental or consequential damages so the above limitation may not apply to you. Some states do not allow limitations on how long an implied warranty lasts, so the above limitation may not apply to you.

**The Dealer is not an agent for Spot Zero, except for the purpose of administering the above warranty to the extent herein provided. Spot Zero does not authorize the dealer or any other person to assume for Spot Zero any liability in connection with such warranty, or any liability or expense incurred in the replacement or repair of its products other than those expressly authorized herein. Spot Zero shall not be responsible for any liability or expense except as is specifically authorized and provided herein.** Spot Zero reserves the right to improve its products, through changes in design or material without being obligated to incorporate such changes in products of prior manufacture. Spot Zero can make changes at any time in design, materials, or part of units of anyone, model year, without obligation or liability to owners of units of the same year's model of prior manufacture.

This warranty gives you, the purchaser/owner, specific legal rights, and you may also have other rights which vary from state to state.



# OWNER'S LIMITED WARRANTY

## **SECTION II**

### **WHAT'S NOT COVERED**

**What does this Limited Warranty not cover?**

**This Warranty Shall Not Apply to:**

1. Failures resulting from improper installation or use contrary to instructions.
2. Failures resulting from abuse, misuse, accident, fire, or submergence.
3. Any part manufactured by Spot Zero, which shall have been altered to impair its original characteristics.
4. Any parts which fail as a result of misuse, improper application, or improper installation.
5. Items not manufactured by Spot Zero, i.e., items, which are purchased from another manufacturer and supplied as received by Spot Zero without alteration or modification except as any part of a Spot Zero manufactured unit or component.
6. Components or parts used by or applied by the purchaser, as an integral part of products not manufactured by Spot Zero.
7. Labor resulting from difficult access to a Spot Zero product. The original installer or OEM is responsible for accessibility of unit.
8. Leaks due to improper installation of system, for example: hose clamps, fittings, flare nuts, quick disconnects.
9. Freight Damage.
10. Pumps that have been run dry, are water damaged or have blown freeze plugs.
11. Pumps with cracked heads.
12. Pump seals are not covered.
13. UV light bulbs are not covered.
14. Sea strainer elements are not covered.
15. Cartridge filter elements are not covered.
16. Sand & gravel in a multi-media filter are not covered.
17. Pump packing assemblies are not covered.
18. Pump valve assemblies are not covered.
19. Pump crankcase oil is not covered.
20. Gauge instrument calibration is not covered.
21. Fuses are not covered.
22. Valve seals and packings are not covered.
23. Exterior corrosion is not covered.
24. Membrane elements are not covered.
25. Logic boards with water damage.
26. Logic boards with blown MOV's (Power Surge)
27. Mis-programmed displays.
28. Displays or remotes with water damage.
29. Failures due to improper winterization.
30. Unit damage as a result of improper return packaging.
31. Travel costs are included in the hourly labor allowances and should not be billed as a separate item without preapproval from the factory.

Installation and application of Spot Zero components are not warranted by Spot Zero, because Spot Zero has no control or authority over the selection, location, application, or installation of these components.

## OWNER'S LIMITED WARRANTY

### **SECTION III** **COVERAGE PERIOD**

#### **What is the period of coverage?**

SEE TABLE OF LIMITED WARRANTY PERIODS BELOW.

**How does one determine when the Limited Warranty Period begins?** All Spot Zero products bear a data plate on which there are model and serial numbers. The date of manufacture of the product can be determined by Spot Zero based on the serial number on the product. To determine whether any Spot Zero component is in warranty, proceed as follows:

1. Determine the model and serial number on the data plate located on the product. Write or call the Spot Zero Customer Service Department to obtain the manufacture date of the product. The hours of the Customer Service Department are 8:00 a.m. - 5:00 p.m. (USA, Eastern Standard Time Zone) Monday through Friday excluding holidays.
2. It is possible that a considerable time lag exists between the date a product or component is manufactured and the date it is put in service. In such instances, the date of manufacture could indicate that the item is out of warranty. However, based on the date the equipment is first put in service, the item may still be covered by the Spot Zero Limited Warranty. For proof of date put in service, Spot Zero will require a copy of the bill of sale of the Spot Zero equipment from the installer or new boat dealer to the original owner.

# OWNER'S LIMITED WARRANTY

## SECTION IV

### GETTING COVERED WARRANTY SERVICE

#### How does the purchaser/owner get warranty service?

**Please read the following Warranty Procedure:** If the failure of a Spot Zero component is determined to be covered under the Spot Zero warranty and the time in service is determined to be within the warranty time limit, the owner has the following three options:

1. Preferred option: Have a Spot Zero authorized Servicing Dealer, perform the work needed. The customer needs to call Spot Zero Customer Service Department for a recommendation as to the closest dealer. If the customer already knows an authorized servicing dealer, the dealer should be contacted directly.
2. Second option: If the customer contacts Spot Zero Service Department for a Servicing Dealer and Spot Zero has no one in that particular area, Spot Zero will authorize the use of a local service company and Spot Zero will work with the local company to assist in any way possible.

The customer may contact the Spot Zero Service Department at 1(800) 542-2477, Monday-Friday, 8:00am - 5:00pm.

### TABLE OF LIMITED WARRANTY PERIODS

#### Important Notes Regarding Product Start-up/ Commissioning:

1. Warranty periods begin from the date of possession of the boat/vessel by the first owner if OEM installed or date of installation if dealer installed, but not to exceed three (3) years from date of production of the product. However, if the product is started for any reason by the OEM or dealer, notwithstanding any provision to the contrary, the warranty period will be for a period of one (1) year commencing from the date that the product was started by the OEM or dealer. The warranty is transferable and will carry the remainder of the original owner's warranty based on the original date of purchase or date of installation.
2. Proof of purchase or installation may be required to verify warranty coverage.
3. Any unit or replacement part installed due to a warranty failure carries the remainder of the original warranty. Warranty coverage does not start over from the repair/replacement date.
4. Warranty coverage shall not exceed three (3) years from the date of production of the product.
5. These warranty periods are effective February 1, 2014.

#### WATER PURIFICATION PRODUCTS:

##### PRODUCT SALE TYPE WARRANTY COVERAGE

**Spot Zero** OEM 1-year warranty, parts and labor, from date of delivery of vessel. Not to exceed 3 years from date of production of product, and subject to **Important Notes above**. Pump warranty, see Pump section.

Dealer Installed 1-year warranty, parts and labor, from date of installation. Not to exceed 3 years from date of production of product, and subject to **Important Notes above**. Pump warranty, see Pump section.

**Sea Xchange** OEM 1-year warranty, parts and labor, Not to exceed 3 years from date of production of product, and subject to **Important Notes above**. Pump warranty, see Pump section.

Dealer Installed 1-year warranty, parts and labor, from date of installation. Not to exceed 3 years from date of production of product, and subject to **Important Notes above**. Pump warranty, see Pump section.

(SE SERIES, SX SERIES FROM DATE OF DELIVERY OF VESSEL. XTC SERIES, CX SERIES)

#### PUMPS, ACCESSORIES, REPLACEMENT PARTS:

##### PRODUCT SALE TYPE WARRANTY COVERAGE

Pumps OEM or Dealer Installed 1 year warranty, parts and labor. Wearable parts such as pump seals, brushes and plastic valves are not covered under warranty.

Dealer Installed and 1 year warranty, parts only. Wearable parts such as pump seals, brushes and plastic valves are not covered under warranty.

Accessories OEM, Dealer Installed, 1-year warranty, parts only. Replacement Parts Aftermarket sales. 90-Day warranty, parts only.